

# *robot a coupe*®



**NEW**  
Register  
your product  
on line



**R 8 • R 10 • R 15 • R 20**

**R 8 V.V. • R 10 V.V. • R 15 V.V. • R 20 V.V.**

**Blixer® 8 • Blixer® 10 • Blixer® 15 • Blixer® 20**

**Blixer® 8 V.V. • Blixer® 10 V.V. • Blixer® 15 V.V. • Blixer® 20 V.V.**

# www.robot-coupe.com

## @ Register your product on line

The screenshot displays the Robot-Coupe website's support section. At the top, the navigation bar includes the company logo, links for 'The company', 'Contact us', and 'Restricted Area', and a 'Select your country...' dropdown. Below this, a menu contains 'CATALOGUE', 'SELECTION GUIDE', 'LEAFLETS', 'VIDEOS', 'OUR', and 'SUPPORT' (the latter is circled). A search bar is also present. The main content area is titled 'SUPPORT' and is divided into two columns. The left column, 'Register your product online', provides instructions and a list of required information: product serial number and purchase date. A 'Register my product now' button is circled at the bottom of this column. The right column, 'Access the Robot-Coupe after-sales service', features an authentication form titled 'robot coupe Authentification' with fields for 'Identifiant', 'Mot de passe', and 'Email', along with a 'Mot de passe perdu' link. A 'Pour nous contacter' link is also visible. An 'Access the Robot-Coupe after-sales service' button is located at the bottom of this column.

# robot coupe®

## EU Declaration of Conformity

**Robot-Coupe SNC** declares that the machines identified by their type above, comply with:

- the essential requirements of the following European directives and with the corresponding national regulations :
  - Directive «Machinery» **2006/42/EC**,
  - Directive «Low Voltage» **2014/35/EU**,
  - Directive «Electromagnetic Compatibility» **2014/30/EU**,
  - Directive «Reduction of Hazardous Substances in Electrical Equipment» (RoHS) **2011/65/EU**,
  - Directive «Waste Electrical and Electronic Equipment» (WEEE) **2012/19/EU**,
- regulation **(EC) No 1935/2004** «Materials and Articles intended to come into Contact with Food»,
- regulation **(EU) No 10/2011** «Plastic Materials and Articles intended to come into contact with Food» and all (EU) regulations amending, correcting and/or rectifying it, and entered into force prior to the date of this declaration, namely to date the (EU) regulations No 321/2011, 1282/2011, 1183/2012, 202/2014, 865/2014, 2015/174, 2016/1416 and 2017/752.

- the provisions of the following harmonized European standards and the standards specifying the safety and hygiene requirements:
  - **EN ISO 12100:2010** Safety of machinery – General principles for design,
  - **EN 60204-1:2006** Safety of machinery – Electrical equipment of machines,
  - **EN 60529** Degrees of protection provided by enclosures (IP Code):
    - IP 55 for the electric controls,
    - IP 34 for the other parts of the machine,
- and according to the category of the apparatus, with the provisions of the following harmonized European standards specifying the safety and hygiene requirements:
  - **EN 454:2015**.....Planetary Mixers,
  - **EN 1678**.....Vegetable Cutting Machines (and Juice Extractors),
  - **EN 12852**.....Food Processors and Blenders,
  - **EN 12853**.....Hand-Held Blenders and Whisks (Power Mixers),
  - **EN 13208**.....Vegetable Peelers,
  - **EN 13621**.....Salad Dryers,
  - **EN 14655**.....Baguette Slicers.

«R015»

Montceau-en-Bourgogne, on June 21, 2017

Alain NODET  
Industrial Director



# SUMMARY

## WARRANTY

## IMPORTANT WARNING

**YOU HAVE JUST PURCHASED A BLIXER® OR A CUTTER MIXER R 8 • R 10 • R 15 • R 20 • R 8 V.V. • R 10 V.V. • R 15 V.V. • R 20 V.V. • Blixer® 8 • Blixer® 10 • Blixer® 15 • Blixer® 20 • Blixer® 8 V.V. • Blixer® 10 V.V. • Blixer® 15 V.V. • Blixer® 20 V.V.**

## SWITCHING ON THE MACHINE

- Advice on electrical connections
- Control panel

## ASSEMBLY

- Machine
- Blade (Cutter only)

## USES AND EXAMPLES

## OPTIONS (Cutter only)

- Stainless-steel mini bowl
- Serrated blade - Fine serrated blade
- Vacuum kit R-Vac®

## HYGIENE

## CLEANING

- Motor unit
- Bowl
- Blade
- Scraper arm (Blixer® only)

## MAINTENANCE

- Dismantling the blade assembly
- Mini bowl blade (Cutter only)
- Scraper arm (Blixer® only)
- Blades
- Seal
- Lid seal

## DIAGNOSTIC SYSTEM

## OPERATING INSTRUCTIONS FOR THE VACUUM KIT R-VAC® (Cutter only)

## FITTING AND USING THE BLADE ASSEMBLY

## TECHNICAL SPECIFICATIONS

- Weight & Dimensions
- Working height
- Noise level
- Electrical data

## SAFETY

## STANDARDS

## TECHNICAL DATA

- Exploded views
- Electrical and wiring diagrams

# ROBOT-COUCPE S.N.C., LIMITED WARRANTY

Your new ROBOT-COUCPE appliance is warranted to the original buyer for a period of one year from the date of sale if you bought it from ROBOT-COUCPE S.N.C.

If you bought your ROBOT-COUCPE product from a distributor your product is covered by your distributor's warranty (Please check with your distributor terms and conditions of the warranty).

The ROBOT-COUCPE S.N.C. limited warranty is against defects in material and/or workmanship.

## THE FOLLOWING ARE NOT COVERED BY THE ROBOT-COUCPE S.N.C. WARRANTY:

**1** - Damage caused by abuse, misuse, dropping, or other similar damage caused by or resulting from failure to follow assembly, operating, cleaning, user maintenance or storage instructions.

**2** - Labour to sharpen and/or replacements for blades which have become blunt, chipped or worn after a normal or excessive period of use.

**3** - Materials or labour to replace or repair scratched, stained, chipped, pitted, dented or discoloured surfaces, blades, knives, attachments or accessories.

**4** - Any alteration, addition or repair that has not been carried out by the company or an approved service agency.

**5** - Transportation of the appliance to or from an approved service agency.

**6** - Labour charges to install or test new attachments or accessories (i.e., bowls, discs, blades, attachments) which have been arbitrarily replaced.

**7** - The cost of changing direction-of-rotation of three-phase electric motors (installer is responsible).

**8** - SHIPPING DAMAGES. Visible and latent defects are the responsibility of the freight carrier. The consignee must inform the carrier and consignor immediately, or upon discovery in the case of latent defects.

KEEP ALL ORIGINAL CONTAINERS AND PACKING MATERIALS FOR CARRIER INSPECTION.

Neither ROBOT-COUCPE S.N.C. nor its affiliated companies or any of its distributors, directors, agents, employees, or insurers will be liable for indirect damage, losses, or expenses linked to the appliance or the inability to use it.

**The ROBOT-COUCPE S.N.C. warranty is given expressly and in lieu of all other warranties, expressed or implied, for merchantability and for fitness toward a particular purpose and constitutes the only warranty made by ROBOT-COUCPE S.N.C. France.**

# RECOMMENDATIONS CONCERNING THE INSTALLATION OF VARIABLE-SPEED APPLIANCES AND PERSONAL SAFETY

These recommendations apply to machines equipped with an induction motor and a single-phase or three-phase wobbulator.

## NB:

- The electrical circuit and the protective devices must comply with national regulations.
- The machine must be wired in by a qualified electrician.

## Protecting your appliance

- Like all electronic devices, wobulators include components that are sensitive to electrostatic discharges (ESDs). Before conducting any work on these wobulators, technicians must therefore rid themselves of electrostatic charges.
- The machine must be disconnected from the mains supply before any internal connection operations are carried out.
- Repeatedly switching on the appliance will cause the wobbulator to overload and may result in its destruction. After the machine has been switched off, you must wait for 3 minutes before switching it back on again.

## 50 or 60 Hz single-phase power supply

- The appliance runs on single-phase or three-phase current as far as the variator, which turns the current into variable frequency three-phase current to supply the motor.

- You must connect the machine to a 200-240 V / 50 or 60 Hz single-phase alternating current supply with an earthed socket. A higher voltage will destroy the wobbulator.
- The earthed socket ensures operator safety.

## Circuit interrupters ensuring user safety

Ground fault circuit interrupters (GFCIs) intended for variable-speed appliances need to be selected with great care in order to ensure operator safety. GFCIs may be sensitive to alternating current (type AC), impulse current (type A) or all currents (type B).

**Danger !** Wobulators feature a bridge-connected rectifier of the mains supply voltage. For this reason, in the event of an earth contact, a continuous fault current may fail to trip a differential circuit breaker that is only sensitive to alternating current (type AC).

It is therefore advisable to use a GFCI that is sensitive to impulse current (type A), identified by the following symbol: .

**Caution:** *these GFCIs may go under different names, according to the manufacturer.*

Appliances with wobulators produce a fault current on the earth wire. This current may be sufficient to trip the differential circuit breaker unnecessarily. This may occur if :

- Several variable-speed appliances are connected to the same GFCI.
- The appliance produces a fault current that is above the GFCI's actual trip threshold.

**Caution:** *As there are manufacturing tolerances, the actual trip threshold of a GFCI will be between 50% and 100% of its theoretical nominal threshold. Should a problem arise, measure the fault current and the GFCI's actual trip threshold.*

You can begin by consulting the characteristics of your appliance in the table below:

Appliance	Mains supply	Conductor Cross-section (mm <sup>2</sup> )	GFCI (Ph + N or 3 Ph)	
			Gauge (A)	Threshold (mA)
R 8 V.V. Blixer® 8 V.V.	200 - 240V 50 or 60 Hz <b>single-phase</b>	6	25	30 mA
R 10 V.V. Blixer® 10 V.V.				
R 15 V.V. Blixer® 15 V.V.	380 - 440V 50 or 60 Hz <b>Three-phase</b>	2,5	20	
R 20 V.V. Blixer® 20 V.V.				

Appliance	Mains supply	Conductor Cross-section (mm <sup>2</sup> )	GFCI (Ph + N or 3 Ph)	
			Gauge (A)	Threshold (mA)
R 8 V.V. Blixer® 8 V.V.	200 - 240V 50 or 60 Hz <b>Three-phase</b>	2,5	20	30 mA
R 10 V.V. Blixer® 10 V.V.				
R 15 V.V. Blixer® 15 V.V.		6	25	
R 20 V.V. Blixer® 20 V.V.				

# IMPORTANT WARNING



**WARNING:** In order to limit accidents such as electric shocks or personal injury, and in order to limit material damage due to misuse of the appliance, please read these instructions carefully and follow them strictly. Reading the operating instructions will help you get to know your appliance and enable you to use the equipment correctly. Please read these instructions in their entirety and make sure that anyone else who may use the appliance also reads them beforehand. Our equipment is designed for professional use and must not be used by children under any circumstances.

## UNPACKING

- Carefully remove the equipment from the packaging and take out all the boxes or packets containing attachments or specific items.
- **WARNING** - some of the tools are very sharp e.g. blade, discs... etc.

## INSTALLATION

- We recommend you install your machine on a perfectly stable solid base.

## CONNECTION

- Always check that your mains supply corresponds to that indicated on the identification plate on the motor unit and that it can withstand the amperage.
- The machine must be earthed.
- With the three-phase version, always check that the blade rotates in an anti-clockwise direction.

## HANDLING

- Always take care when handling the blades or discs - they are very sharp.

## ASSEMBLY PROCEDURES

- Follow the various assembly procedures carefully (see page 8) and make sure that all the attachments are correctly positioned.

## USE

- Do not open the lid until the motor has come to a complete stop.
- Never tamper with the locking and safety systems.
- Never put a hand object in the bowl while the machine is operating.
- Never force the ingredients down with your hands.
- Do not overload the machine.

## CLEANING

- As a precaution, always unplug your appliance before cleaning it.
- Always clean the appliance and its attachments at the end of each cycle.
- Never place the motor unit in water.
- For parts made of aluminum alloys, use cleaning fluids suitable for aluminum.

- For plastic parts, do not use detergents that are too alkaline (i.e., containing too much caustic soda or ammonia...)
- Robot-Coupe can in no way be held responsible for the user's failure to follow the basic rules of cleaning and hygiene.

## MAINTENANCE

- Before opening the motor housing, it is absolutely vital to unplug the appliance.
- Check the seals and washers regularly and ensure that the safety devices are in good working order.
- It is particularly important to maintain and check the attachments since certain ingredients contain corrosive agents e.g. citric acid.
- Never operate the appliance if the power cord or plug has been damaged in any way or if the appliance fails to work properly or has been damaged in any way.
- Do not hesitate to contact your local Maintenance Department if something appears to be wrong.

## YOU HAVE JUST PURCHASED A BLIXER® OR A CUTTER MIXER

R 8 • R 10 • R 15 • R 20 •

R 8 V.V. • R 10 V.V. • R 15 V.V.

• R 20 V.V. • Blixer® 8 •

Blixer® 10 • Blixer® 15 •

Blixer® 20 • Blixer® 8 V.V. •

Blixer® 10 V.V. • Blixer® 15 V.V.

• Blixer® 20 V.V.

Its simple design means that all parts which are handled frequently can be easily assembled, or removed for maintenance or cleaning.

To make things easier for you, this instructions manual has been divided according to the various assembly operations.

To make things easier for you, this instructions manual has been divided according to the various assembly operations.

**This manual contains vital information designed to help the user get the most out of his or her cutter mixer.**

Consequently, we strongly advise you to read the manual carefully before using your machine. We have also included a few examples to help you get the feel of your new machine and appreciate its countless advantages.

## SWITCHING ON THE MACHINE



### WARNING

THIS APPLIANCE MUST BE PLUGGED INTO AN EARTHED SOCKET (RISK OF ELECTROCUTION).

### • ADVICE ON ELECTRICAL CONNECTION

Before plugging in, check that your power supply corresponds to that indicated on the machine rating plate.

R 8 • R 10 • R 15 • R 20 • R 8 V.V. • R 10 V.V. •

R 15 V.V. • R 20 V.V.

Blixer® 8 • Blixer® 10 • Blixer® 15 • Blixer® 20 •

Blixer® 8 V.V. • Blixer® 10 V.V. • Blixer® 15 V.V. •

Blixer® 20 V.V. Three phase

Robot-Coupe supplies models adapted to the following types of electrical mains supply:

220V/ 60 Hz / 3

230V/ 50 Hz / 3

380V/ 60 Hz / 3

400V/ 50 Hz / 3

The machine is supplied with a cable to which you simply attach the appropriate electrical plug for your system or wire to your isolator box, if wiring to an isolator box this should be undertaken by a qualified electrician. The cable has four wires, one earth wire, plus three phase wires.

### If you have a 4-pin plug:

1) Connect the green and yellow earth wire to the earth pin.

2) Connect the three other wires to the remaining pins.

As **ROBOT-COUPÉ** doesn't require a neutral connection, if you have a five-pin plug, the central pin will not be used.

**Switch on the empty machine, making sure that the blade is rotating properly in an anti-clockwise direction.**

If this is not the case, contact your technical support service.

R 8 V.V. • R 10 V.V.

Blixer® 8 V.V. • Blixer® 10 V.V. Single phase

Robot-Coupe supplies models adapted to the following types of electrical mains supply:

220V/ 60 Hz / 3

230V/ 50 Hz / 3

200V - 240V / 50 Hz or 60 Hz / 1

The appliance is supplied with a bare power cord so that you can fit a plug that corresponds to your particular mains supply. This cord comprises three conductors: an earth wire, a neutral wire and a live wire.

### • CONTROL PANEL

R 8 • R 10 • R 15 • R 20

Blixer® 8 • Blixer® 10 • Blixer® 15 • Blixer® 20:

Red switch  = "Off" button

Green switch  = "On" button 1<sup>st</sup> speed (1,500 or 1,800 rpm)

Green switch  = "On" button 2<sup>nd</sup> speed (3,000 or 3,600 rpm)

Black switch  = Pulse control

Green indicator = safety indicators

R 8 V.V. • R 10 V.V. • R 15 V.V. • R 20 V.V.

Blixer® 8 V.V. • Blixer® 10 V.V. • Blixer® 15 V.V. • Blixer® 20 V.V. :

Speed variation from 300 to 3,500 rpm.

Red switch  = "Off" button

Green switch  = "On" button

Black switch  = Pulse control

Potentiometer = speed regulation

Green indicator = safety indicators



## ASSEMBLY

### • MACHINE



1) With the motor base facing you, position the bowl on the motor shaft so that the handle on your left is near the control panel.

2) Pressing down on the handles, turn the bowl firmly in an anticlockwise direction until it locks into place.



3) Position the blade mounted on the motor shaft. Then rotate it so that it is lowered right down to the bottom of the bowl. Always check that the blade is correctly positioned at the bottom of the bowl before adding the ingredients to be processed.

The R 8 is supplied with a smooth 2-blade assembly. The R 10, 15 and 20 are supplied with a smooth 3-blade assembly.

The Blixer® 8 is supplied with a fine-serrated 2-blade assembly.

The Blixer® 10, 15 and 20 models are supplied with a fine-serrated 3-blade assembly.

### • If the lid parts are already assembled:

4) Place the lid assembly in the correction position. Next, insert the metal pin as far as it will go.



### • If the lid parts have not been assembled:

4) Position the end of the lid arm in the hinge. Next, insert the metal pin as far as it will go (photo 1). Push the lid guide through the lid arm hole and screw the cone into the top of the guide (photo 2). Clip the lid onto the guide and turn it so that the dimples are beneath the lid arm (photo 3).

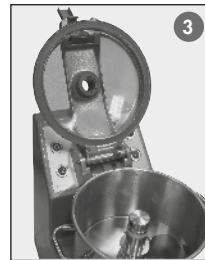

5) Close the lid by securing the locking hook to the edge of the bowl and pushing the handle down.

The machine is now ready for operation.

The green indicator light should be on.



## WARNING

There is a green safety indicator light on the control panel of the motor unit. If this green light does not come on, consult the relevant paragraph. A flashing green light means that the conditions for the safe operation of the machine have not all been met. Check that the bowl, lid arm and lid are all correctly positioned. As soon as the light stops flashing and stays on, you can use your machine.

### • BLADE (Cutter only - see diagram, page 15)

For fine stuffing, mousse and emulsions, use the smooth blades.

There should not be any rings between the base of the blade holder and the lower blade.

You must always insert the small ring between the blade holder base and the lower blade (bowl base assembly) before carrying out mincing tasks. In order to control the mincing process and prevent the meat from overheating, always use the «pulse» switch (coarse mincing assembly).

For grinding or kneading, use serrated blades and do not fit any rings between the lower blade and the base of the blade shaft.

Use fine serrated blades to chop parsley and do not insert any rings between the blade holder base and the lower blade.

## USES & EXAMPLES

### CUTTER-MIXER

USES	Max processing quantity (kg)				Processing time (mn)	Speed (rpm) see summary
	R 8	R 10	R 15	R 20		
<b>CHOP</b>						
<b>• MEAT</b>						
Hamburger/ steak tartare	3	4	6	8	4	1 speed
Sausage meat / tomatoes	3	4	6	8	3	1200/1500
Terrine / pâté	2	4	8	10	4	1200/1500
White pudding / liver mousse	4	5	9	11	4	2 speeds
Galantine (stuffing + thin slices)	2	3	8	10	4	2 speeds
<b>• FISH</b>						
Brandade / quenelle	4	5	7	9	5	3000
Terrines	4	5	9	11	5	3000
<b>• VEGETABLES</b>						
Garlic / parsley / onion / shallots	1 to 3	1 to 3	2 to 5	2 to 6	3	3 speeds
Soup / vegetable purées	4	5	9	11	4	1500/2000
<b>• FRUIT</b>						
Compotes / fruit purée	4	5	9	11	4	1500/2000
<b>EMULSIFY</b>						
Mayonnaise / aïoli	4	5	9	11	3	4 speeds
Rémoulade sauce	4	5	9	11	5	600/1500
Snail / salmon butter	2	3	5	7	4	600/1500
<b>KNEAD</b>						
Shortcrust pastry / shortbread	4	5	7	9	4	4 speeds
Flaky pastry	4	5	7	9	4	900/1500
Brioche + Raisin dough	4	5	7	9	4	900/1500 + 300
<b>GRIND</b>						
Almond paste / nuts	2	3	5	6	6	900/1500
Seafood / ice cubes	2	3	6	8	5	900/1500
Breadcrumbs	2	3	5	6	4	900/1500

The cutter-mixer has numerous other applications. The above examples are given for guidance and may vary according to the quality of ingredients or recipes.

### SUMMARY:

#### Dual-speed cutter

- **1 speed/3 speeds/4 speeds:** 1500 or 1800 rpm.
- **2 speeds:** preparation at 1500 or 1800 rpm, finishing touches at 3000 or 3600 rpm.

#### Variable-speed cutter:

- **1 speed:** 1200 to 1500 rpm.
- **2 speeds:** finishing touches at 3500 rpm.
- **3 speeds:** 1500 to 2000 rpm.
- **4 speeds:** 600 to 1500 rpm.

**NB:** Use the lowest available speed for mixing ingredients

### BLIXER®

#### HOSPITAL USES

##### SPOON FEEDING

- Minced foods: meat, fish etc...
- Mousses: vegetables, fish etc...
- Vegetable purees
- Compotes of stewed fruit

##### SEMI-LIQUID FEEDING

This simply entails diluting spoon-feeding preparations:

- Minced meat + gravy
- Soups / creamed soups
- Puree + liquid (broth, milk, etc.)
- Fruit compotes + syrup or water

##### LIQUID FEEDING (for use via tubes)

- Soups and any preparations that can be liquidized.

#### DELICATESSEN USES

- Butter mixtures: snail butter, salmon butter, anchovie butter...
- Sauces: green sauce, mayonnaise, remoulade, aïoli, emulsified sauces with tomatoes, cream, parsley...
- Grinding: lobster, scampi, seashells...

#### PHARMACEUTICAL AND CHEMICAL LABORATORY USES

- Grinding: herbs, seeds, powders, tablets...
- Mixing: homogeneization of creams, ointments, mixed components, varied ingredients...

## OPTIONS (Cutter only)

### STAINLESS-STEEL MINI BOWL

**Optional extra:** 3.5-litre mini bowl for the R 8 and 4-litre mini bowl for the R 10 and R 15, boasting at least 2 speeds 1,500 and 3,000 rpm (patented system exclusive to Robot-Coupe) plus 100% stainless steel blade assembly, easily taken apart, for making quick sauces, chopping herbs and carrying out all those other last-minute tasks.

### STAINLESS-STEEL MINI BOWL WITH 3.5-LITRE CAPACITY FOR R 8 AND 4-LITRE CAPACITY FOR R 10 • R 15

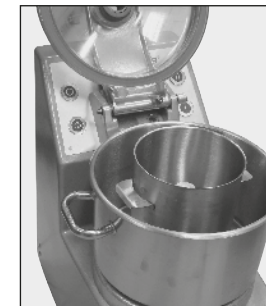

1) Place the mini bowl over the chimney of the large bowl, then turn it until it fits into position over the lug. The mini bowl handles should now be lined up with those of the large bowl.

2) Next, slot the 100% stainless-steel blade assembly over the motor shaft and place the mini lid on top of the mini bowl to avoid splashing. Next, close the machine lid.



### SERRATED KNIFE - FINE SERRATED KNIFE

The blade holder can be fitted either with two coarse serrated blades or with two fine serrated ones.

The serrated blades are mainly used :

- for making pastry
- for grinding.

The fine serrated blades are mainly used for:

- chopping parsley
- blending

#### • VACUUM KIT R-VAC®

Your cutter can perform vacuum processing without any need for modifications.

Simply assemble the vacuum kit R-VAC®, patented by ROBOT-COUCPE on to the lid and connect it to a vacuum pump (see instructions page 32).

If you already have a vacuum packing machine, you can connect the kit to the vacuum pump on this machine.

The R-VAC® kit was specifically designed so that liquids can be added to the mixture during processing, whilst keeping the food under vacuum.

## HYGIENE

#### • WARNING: NEVER USE PURE BLEACH.

- Correctly diluate the detergent following the instructions given by the manufacturer which are generally printed on the packaging.
- If necessary, well rub.
- Let the detergent operate if needed.
- Rinse meticulously.
- Well dry with an unique use cloth.

## CLEANING



### WARNING

**As a precaution, always unplug your appliance before cleaning it (hazard of electrocution) and handle the blades with care (hazard of injury).**

#### • MOTOR UNIT

**Never immerse the motor unit in water. Clean it with a damp cloth or sponge**

#### • BOWL

After removing the lid, release the bowl by pressing the trigger built into the handle. It can then be lifted vertically from the motor support. If the bowl contains a liquid preparation, leave the blade assembly inside to ensure that it remains completely watertight.

If the food has a solid consistency, remove the knife and empty the bowl.

Replace the bowl, place the blade on the shaft and switch on the machine in order to remove any mixture which may have stuck to the blade.

The bowl can be prewashed by pouring hot water into it and running the machine for a few minutes.

#### • BLADE (See page 33 and 34)

The R 8 is supplied with a smooth 2-blade assembly. The R 10, 15 and 20 are supplied with a smooth 3-blade assembly.

The Blixer® 8 is supplied with a fine-serrated 2-blade assembly.

The Blixer® 10, 15 and 20 are supplied with a fine-serrated 3-blade assembly.

The 100% stainless-steel blade assemblies of our cutter and Blixer® can be taken apart for easy cleaning

After cleaning the blade, always dry well to prevent rusting.



### IMPORTANT

**Check that your detergent is suitable for cleaning the plastic parts.**

**Certain washing agents are too alkaline (e.g. high levels of caustic soda or ammonia) and totally incompatible with certain types of plastic, causing them to deteriorate rapidly.**



### IMPORTANT

**Like the bowl and lid, the blade assembly should also be removed for cleaning after use.**

**Always dry all the metal parts carefully, especially the blades, to avoid oxidization**

#### • SCRAPER ARM (Blixer® only)

To clean the scraper arm, dismantle it as follows. Hold the scraper arm in one hand and the hub in the other hand (drawing 1). Press the two pieces one on the other, and turn the handle of 45° anticlockwise (drawing 2). Then it is possible to pull out the two pieces (the scraper arm and the handle) from the lid and clean them (drawing 3).

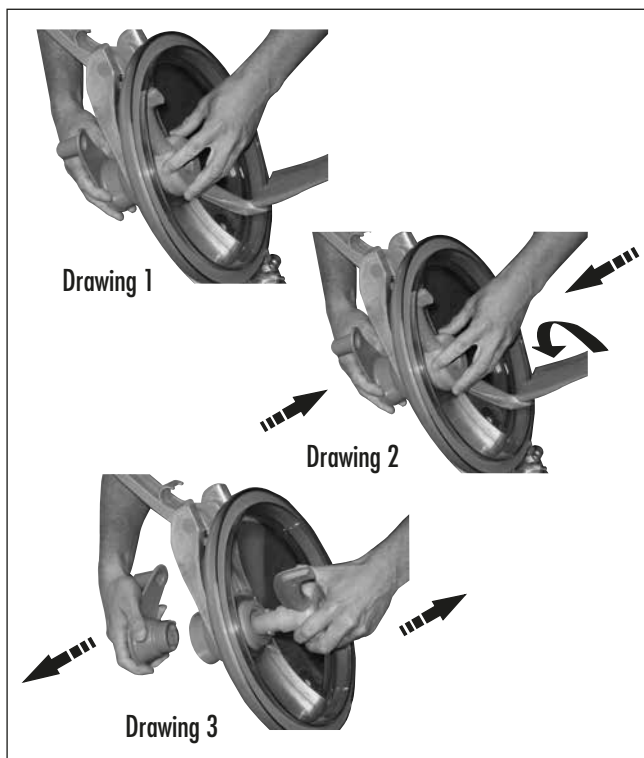

- Slide the cutter right down the motorshaft.
- Make sure that the lower blade is resting on top of the blade tool.



- Loosen the locking nut with the metal wrench.

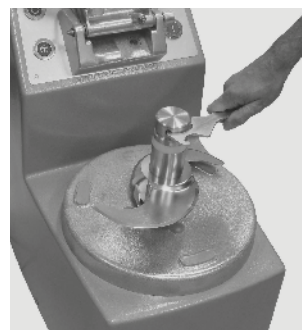

- To replace the knife, simply do the same in reverse.

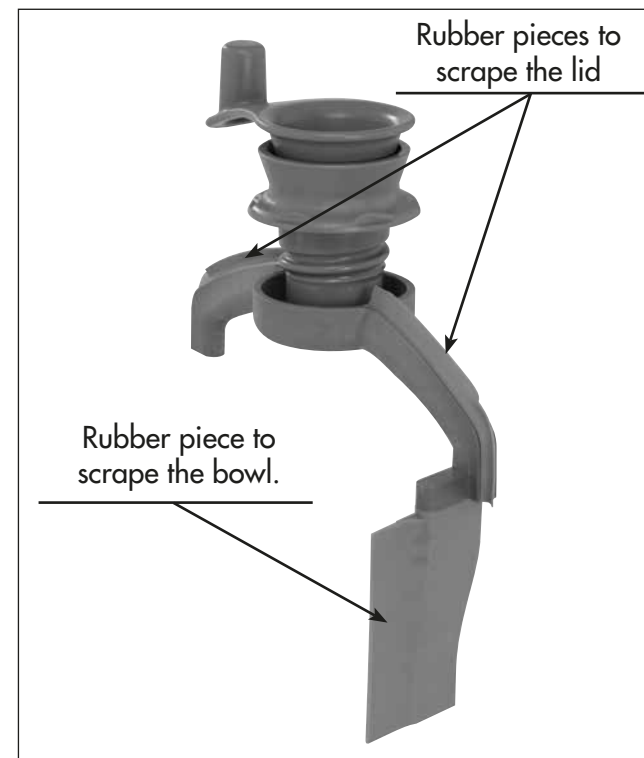

## MAINTENANCE

### • DISMANTLING THE BLADE ASSEMBLY

- R 8 • R 10 • R 15 • R 20 • Blixer® 8 • Blixer® 10
- Blixer® 15 • Blixer® 20 blade

- Disconnect the machine.
- Remove the bowl.
- Position the blade tool on the motor shaft.

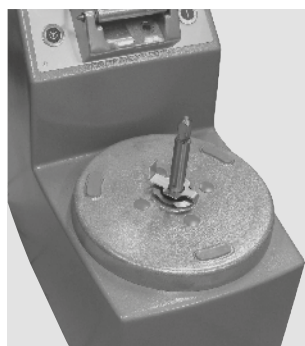

### • MINI BOWL BLADE (Cutter only)

A special tool designed to make it easier to remove the blade assembly from the mini bowl is supplied with the machine.



### • SCRAPER ARM (Blixer® only)

The scraper arm is equipped with rubber pieces which are wearing parts. They should be replaced occasionally to always ensure an optimum efficiency of the scraper arm. These pieces are easy to dismantle and to reassemble.

### • BLADES

**Only the blades on cutters R 8/R 10/R 15 and R 20 can be sharpened.**

It is strongly recommended, after each use, to give the blades a quick sharpen with a sharpening steel, especially after cutting parsley.

They should then be sharpened properly once a month with the very fine whetstone that comes with the appliance.

The quality of the cut depends mainly on the sharpness of your blades and the degree of wear.

The blades are actually wearing parts, which should be replaced occasionally to ensure consistent quality in the final product.

• **SEAL**

The seal on the motorshaft should be lubricated regularly using a food safe lubricant.

In order to keep the motor completely watertight, it is advisable to check the gasket regularly for wear and tear and replace if necessary.

• **LID SEAL**

The lid is designed to be completely watertight. In order to ensure that it remains that way, you may have to change the seal occasionally, depending on how regularly you use your machine.

If you do not use your machine regularly, between uses it is advisable to leave the lid open to preserve all these features.

**DIAGNOSTIC SYSTEM**

Your appliance is equipped with a light that indicates the operational status of your machine:

- **no green light:** see paragraph 1.
- **green flashing light:** see paragraph 2.
- **continuous green light:** your appliance is ready to run.

• **DUAL-SPEED VERSION**

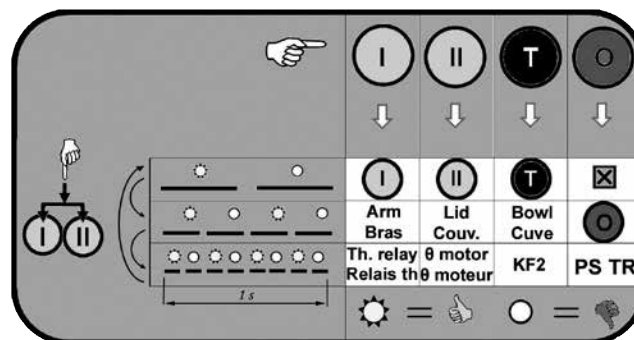

**REMEMBER**

**Always switch your machine off before carrying out any cleaning or maintenance, All repair and maintenance work must be carried out by a qualified technician.**

**1) No green light**

This means that either your appliance is switched off or there is a problem with the power supply.

Measure the voltage at the power outlet and check that the plug is correctly wired.

(If the problem persists, see\*).

**2) Flashing green light**

**REMEMBER**

**After switching your appliance on, open and close the lid to check that the machine is working properly. If it is, the green light will stop flashing and stay on.**

One or more of the safety devices is not responding. These safety devices comprise 3 presence sensors, a thermal relay and a motor overload protector.

The indicator light and the buttons offer a means of testing the machine's components and safety devices before performing any sort of intervention.

There is no point continuing with the test once you have detected a fault. Instead, rectify the problem and start the test afresh.

• **General points:**

The enclosed table is intended to help you follow the test procedure.

Each blank square corresponds to the element being tested.

Each of the 4 columns corresponds to one of the 4 buttons pressed one after the other by the operator.

The 3 rows correspond to the 3 successive test levels. You can change the level by simultaneously pressing **buttons I and II**. Each level is indicated by increasingly rapid flashing of the green light: slow for the first level, faster for the second and very fast for the third. To return to testing level 1, the buttons must be simultaneously pressed a further time.

When none of the buttons is being pressed, the light flashes to indicate the testing level. When one of the buttons is continuously pressed, it indicates the result of the relevant test: on = OK, off = problem.

• **Test sequence:**

When the green light flashes, start by pressing button I to test that it is working properly (as the buttons are used to test the machine, it is only logical to check that they themselves are working properly).

Press **buttons II and T** to test that they are working, too.

At this level, **button 0** does not test anything.

Press **buttons I and II** simultaneously to move up to testing level 2, indicated by more rapid flashing of the indicator light. At level 2, **buttons I, II, T and 0** allow you to test the presence sensors of the lid, the base and the bowl, and the contact of **button 0**, respectively.

Press **buttons I and II** simultaneously to move up to testing level 3, indicated by very rapid flashing of the indicator light. At level 3, **buttons I, II, T and 0** allow you to test the thermal relay and the motor overload protector, the mains voltage, the phase-frequency detector, and the location of the jumpers and braking relay, respectively.

Press **buttons I and II** simultaneously to return to the normal flashing speed and therefore to testing level 1.

• **CONTRÔLES - CHECKS**

**Level 1 and level 2 button 0 test:**

If one of the button tests indicates a problem, check the button's contact block and wiring.

**Level 2:**

If the test reveals a problem with one of the presence sensors, check that the removable parts of your cutter mixer (bowl, lid and arm) are all in place. If the problem persists, check the presence sensors themselves and their wiring.

**Level 3:**

If you have not been using your machine intensively, when it may be quite normal for the motor to overheat and trigger the thermal relay and/or overload protector:

- If the test indicates that the thermal relay is faulty, check that the latter is correctly set (automatic position and current intensity in accordance with the diagram);
- If the test indicates that the motor overload protector is faulty, check the latter's wiring;
- If a «voltage» or «Phase + Frequ» error message is displayed, check that the machine is supplied with the correct voltage. Also check that the plug is correctly wired.
- If a «Jumpers + KFR» error message is displayed, check that the location of the configuration jumpers on the board corresponds to that indicated in the electrical diagram, according to the mains supply.

\* If the latter problems persist, the control board must be changed.

• **VARIABLE SPEED VERSION**

The flashing of the green light indicates which element needs to be checked.

A rapidly flashing light indicates that either the base (ISBC) or the lid (ISCO) presence sensor is posing a problem. Press button I to determine which of these two components needs to be checked. If the light continues to flash the same way as before when you press button I, check the lid arm sensor.

If, on the other hand, the light starts to flash more slowly and asymmetrically (longer off than on), check the lid sensor.

Asymmetrical flashing (longer on than off) means that the bowl sensor needs to be checked (ISCU).

Slow flashing means that either the contact of the STOP button (BPA) or the motor protector (PTO) is posing a problem. Press button T to determine which of these two components needs to be checked. If the flashing does not change when you press button T, check the contact of the STOP button.

If, on the other hand, the flashing becomes asymmetrical (longer on than off), check the motor overload protector.

For further details about the tests, see the previous paragraph on dual-speed models.

		Etat LED / LED state Sans action / No action	Presser Press	2 <sup>nd</sup> Etat LED / 2 <sup>nd</sup> LED state Bouton maintenu / Switch press	Contrôle Check
Allumé / ON			/	/	Prêt / Ready
Clignotement	Rapide Fast		BPM		ISBC ISCO
	Clin d'oeil Winking		/	/	ISCU
Blinking	Lent Slow		BPP		BPA PTO
	Eteinte / OFF		/	/	Alimentation Supply

# OPERATING INSTRUCTIONS FOR THE VACUUM KIT R-VAC® (Cutter only)

## 1° ASSEMBLING THE VACUUM KIT R-VAC®

- Insert filter N° 2 into body N° 3
- Screw part N° 1 onto body N° 3 (the tube is fed through body N° 3).

Keep an eye on the position of the O-ring seal when fitting part N° 1. →

Filter N° 2 can be cleaned. →

Check that the openings are in the upper position in order to position nut N° 4. →

## 2° PLACING THE VACUUM KIT R-VAC® ON THE LID

- Insert the vacuum kit into the cone section of the plastic part N° 5. The latter should be screwed into the lid guide N° 6 which, in turn, should be slotted into the aluminium lid arm N° 8. The lid N° 9 should also be clipped onto the lid guide N° 6.

## 3° CLIPPING THE BELL N° 4

- Hold the bell in the palm of your hand and press the pusher N° 7 in with your thumb.
- Fit the nut onto the cylindrical section which juts out over the lid.
- Release button N° 7.
- The pusher should return to its original position. If it does not, press the bell gently so that it automatically clicks into place.
- Check that the bell is properly attached to the tube N° 1, in order to avoid all risk of the bell or kit falling off.

## 4° USING THE VACUUM KIT R-VAC®

- Connect up the vacuum pump to valve A, check that the latter is open (lever in shaft of connector).
- Shut valve B (perpendicular lever).

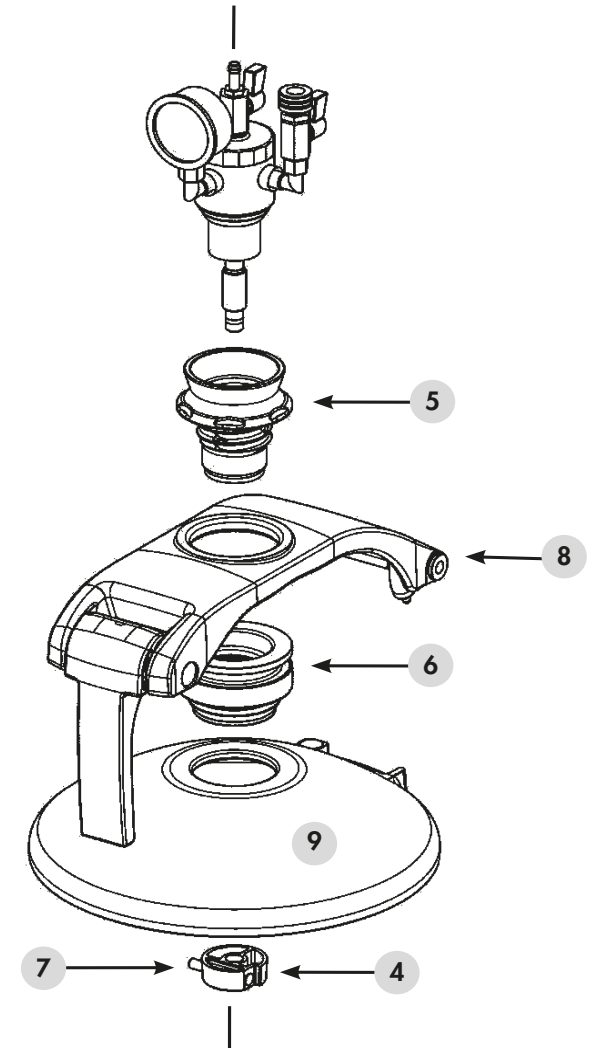

## 5° ADDING LIQUID TO THE MIXTURE

- Attach a tube to valve B.
- Immerse the other end of this tube in the liquid to be added.
- Open valve B slowly ; once the liquid has been added, shut valve B.



## NOTE

Preheat the vacuum pump (approx. 15 minutes) to check that both it and the vacuum kit are working properly. Similarly, leave the pump running for 15 minutes after completing the task in order to evacuate the condensation.

## FITTING AND USING THE BLADE ASSEMBLY (Cutter only)



Screw nut



Plastic ring

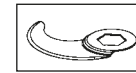

Blade



Long ring



Narrow spacer



Blade shaft

### • 2-BLADE ASSEMBLY:

We recommend you use the two-blade assembly for processing small amounts (less than half the maximum capacity indicated on page 9).

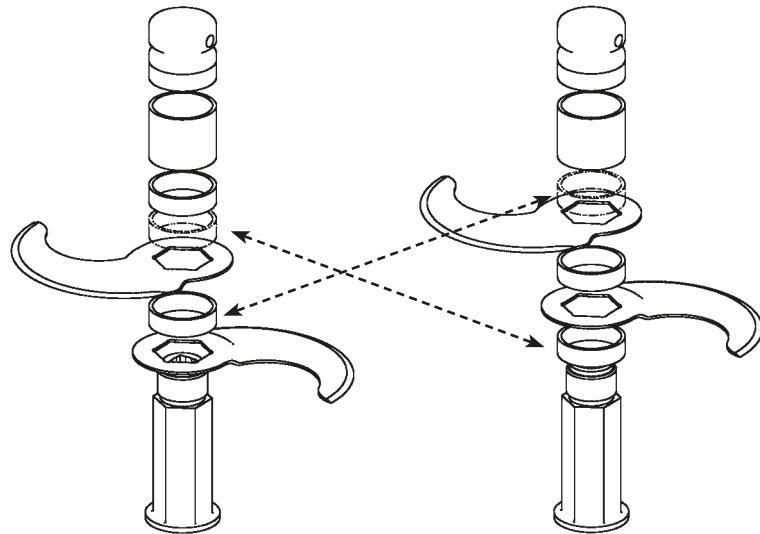

**Position 1 - Bowl base**      **Position 2 - Coarse mincing**  
Correct positioning of 2-blade assembly (top view)

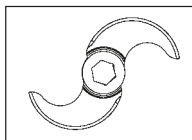

### • 3-BLADE ASSEMBLY:

We recommend you use the 3-blade assembly for processing large quantities of more than half the maximum limit indicated, with the exception of liquid or blended preparations for which we strongly recommend you use the 2-blade assembly. **For preparations of this kind, it is recommended you use the first speed in order to obtain the best results.**

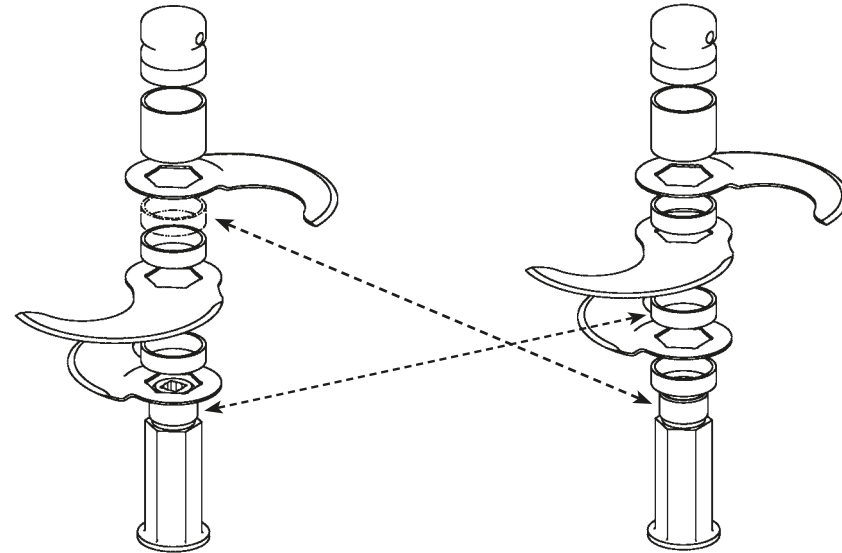

**Position 1 - Bowl base**      **Position 2 - Coarse mincing**  
Correct positioning of 3-blade assembly (top view)

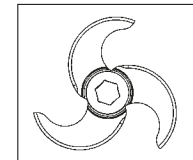

**POSITION 1:** No spacer between lower blade and blade shaft.

- For **fine chopping** and **emulsions**.
- For **grinding** and **kneading**.

**DISMANTLING:**

- Unscrew the screw nut.
- Remove the rings and blades.

**POSITION 2:** With spacer between lower blade and blade shaft.

- For **coarse chopping**.

**MONTAGE:**

- Fit the blades and spacers so that they are the right distance apart, according to the:
  - type
  - weight and
  - volume of the foodstuffs to be processed.

**WARNING:** The plastic ring must be placed under the locking nut.



## FITTING AND USING THE BLADE ASSEMBLY (Blixer® only)



Screw  
nut



Plastic  
ring

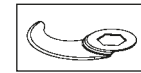

Blade



Long ring



Narrow  
spacer



Blade  
shaft

### • 2-BLADE ASSEMBLY:

We recommend you use the two-blade assembly for processing small amounts.

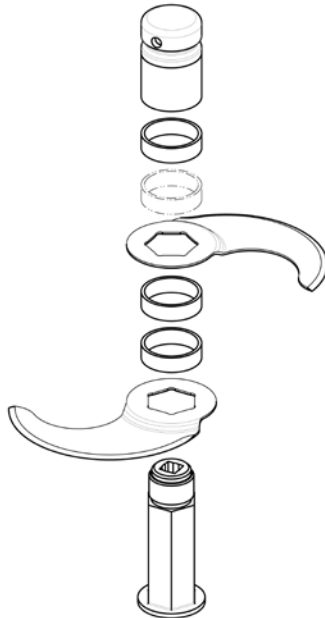

Correct positioning of 2-blade assembly (top view)

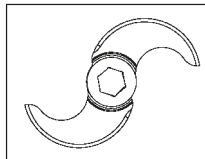

### • 3-BLADE ASSEMBLY: (except Blixer® 8):

We recommend you use the 3-blade assembly for processing large quantities of more than half the maximum limit indicated, with the exception of liquid or blended preparations for which we strongly recommend you use the 2-blade assembly. **For preparations of this kind, it is recommended you use the first speed in order to obtain the best results.**

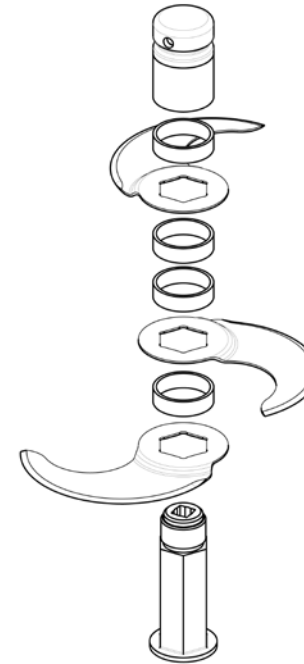

Correct positioning of 3-blade assembly (top view)

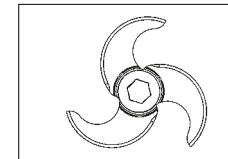

- DISMANTLING:**
- Unscrew the screw nut.
  - Remove the rings and blades.

- MONTAGE:**
- Fit the blades and spacers so that they are the right distance apart, according to the:
    - type
    - weight and
    - volume of the foodstuffs to be processed.

**WARNING:** The plastic spacer goes below the nut + long spacer assembly.

# TECHNICAL SPECIFICATIONS

## • WEIGHT & DIMENSIONS

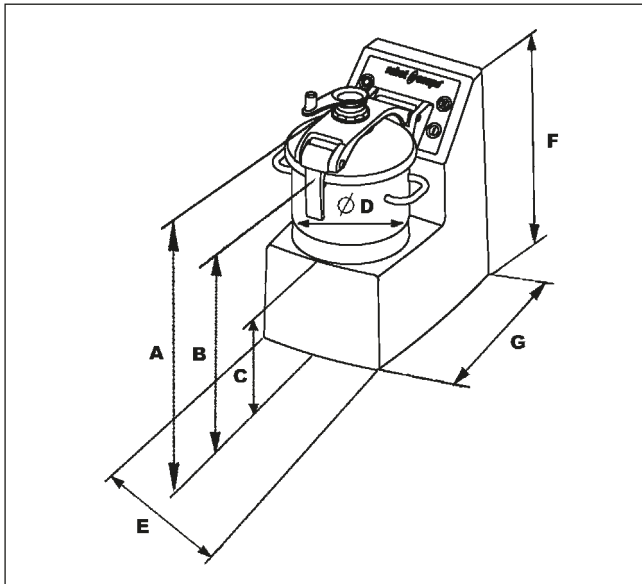

Models	Dimensions (in mm)							Weight (Kg)	
	A	B	C	D	E	F	G	Net	Gross
Blixer® 8 R 8	585	445	255	300	315	525	545	40	52
Blixer® 8 V.V. R 8 V.V.									
Blixer® 10 R 10	660	520	280	300	345	600	560	45	57
Blixer® 10 V.V. R 10 V.V.									
Blixer® 15 R 15	680	540	300	340	370	620	615	49	62
Blixer® 15 V.V. R 15 V.V.									
Blixer® 20 R 20	760	620	315	340	380	700	630	75	88
Blixer® 20 V.V. R 20 V.V.									

## • WORKING HEIGHT

We recommend that you position the Blixer® 8 / 8 V.V. - R 8 / 8 V.V. - Blixer® 10 / 10 V.V. - R 10 / 10 V.V. on a stable worktop so that the upper edge of the large feed head is at a height of between 1.20 and 1.30 m.

We advise you to position your Blixer® 15 / 15 V.V. - R 15 / 15 V.V. - Blixer® 20 / 20 V.V. - R 20 / 20 V.V. on a stable surface. There is no recommended working height since this is a floor-standing model.

## • NOISE LEVEL

The equivalent continuous sound level when the machine is operating on no-load is less than 70 dB(A).

## • ELECTRICAL DATA

R 8 • Blixer® 8 dual-speed Three-phase appliance

Motor	Speed 1 (rpm)	Speed 2 (rpm)	Intensity (Amp.)
230V/50 Hz / 3	1,500		230 V = 8.5 400 V = 4.8
400V/50 Hz / 3		3,000	230 V = 10 400 V = 5.5
220V/60 Hz / 3	1,800		230 V = 10 400 V = 5.5
380V/60 Hz / 3		3,600	230 V = 11 400 V = 6

Monophase or Three phase appliance  
R 8 V.V. • Blixer® 8 V.V.

Motor	Speed (rpm)	Intensity (Amp.)
200 - 240 V/50-60 Hz / 1	300 to 3,500	21
200 - 240 V/50-60 Hz / 3		14.3

R 10 • Blixer® 10 dual-speed Three-phase appliance

Motor	Speed 1 (rpm)	Speed 2 (rpm)	Intensity (Amp.)
230V/50 Hz / 3	1,500		230 V = 10 400 V = 6
400V/50 Hz / 3		3,000	230 V = 11 400 V = 6
220V/60 Hz / 3	1,800		230 V = 10 400 V = 6
380V/60 Hz / 3		3,600	230 V = 11 400 V = 6.5

Monophase or Three phase appliance  
R 10 V.V. • Blixer® 10 V.V.

Motor	Speed (rpm)	Intensity (Amp.)
200 - 240 V/50-60 Hz / 1	300 to 3,500	21
200 - 240 V/50-60 Hz / 3		14.3

R 15 • Blixer® 15 dual-speed Three-phase appliance

Motor	Speed 1 (rpm)	Speed 2 (rpm)	Intensity (Amp.)
230V/50 Hz / 3	1,500		230 V = 13 400 V = 7
400V/50 Hz / 3		3,000	230 V = 12 400 V = 6.5
220V/60 Hz / 3	1,800		230 V = 11 400 V = 6.5
380V/60 Hz / 3		3,600	230 V = 12 400 V = 7

Monophase or Three phase appliance  
R 15 V.V. • Blixer® 15 V.V.

Motor	Speed (rpm)	Intensity (Amp.)
200 - 240 V/50-60 Hz / 1	300 to 3,500	21.7
200 - 240 V/50-60 Hz / 3		11.6

R 20 • Blixer® 20 dual-speed Three-phase appliance

Motor	Speed 1 (rpm)	Speed 2 (rpm)	Intensity (Amp.)
230V/50 Hz / 3	1,500		230 V = 16.3 400 V = 9.4
400V/50 Hz / 3		3,000	230 V = 17.5 400 V = 10.1
220V/60 Hz / 3	1,800		230 V = 16.3 400 V = 9.4
380V/60 Hz / 3		3,600	230 V = 17.3 400 V = 10

Monophase or Three phase appliance  
R 20 V.V. • Blixer® 20 V.V.

Motor	Speed (rpm)	Intensity (Amp.)
200 - 240 V/50-60 Hz / 1	300 to	24.8
200 - 240 V/50-60 Hz / 3	3,500	11.6

- Power shown on data plate.

## SAFETY



### WARNING

The blades are extremely sharp. Handle with care.

This ROBOT-COUPE range of Cutter and Blixer® is equipped with a mechanical safety system and a motor brake. Moreover, the machine will not operate unless the bowl and lid are correctly positioned on the motor base.

The motor stops as soon as the lid is opened.

However, if you are processing liquid ingredients, it is a good idea to stop the machine before opening the lid, to avoid splashing.

To restart the machine, simply close the lid and press the green «On» switch.

These models are fitted with a **thermal failsafe** which automatically switches the motor off if it is overloaded or has been left running for too long.

If this happens, allow the machine to cool completely before restarting.



### WARNING

**Never try to override the locking and safety systems.**

**Never insert an object into the container where the food is being processed.**

**Never push the ingredients down with your hand.**

**Do not overload the appliance.**

**Never switch the appliance on when it is empty.**

## STANDARDS

Consult the declaration of compliance on page \$.

**robotcoupe®**

**R8E - R10E**

N° de série / Serial number

- 512 - - - - -

- 514 - - - - -

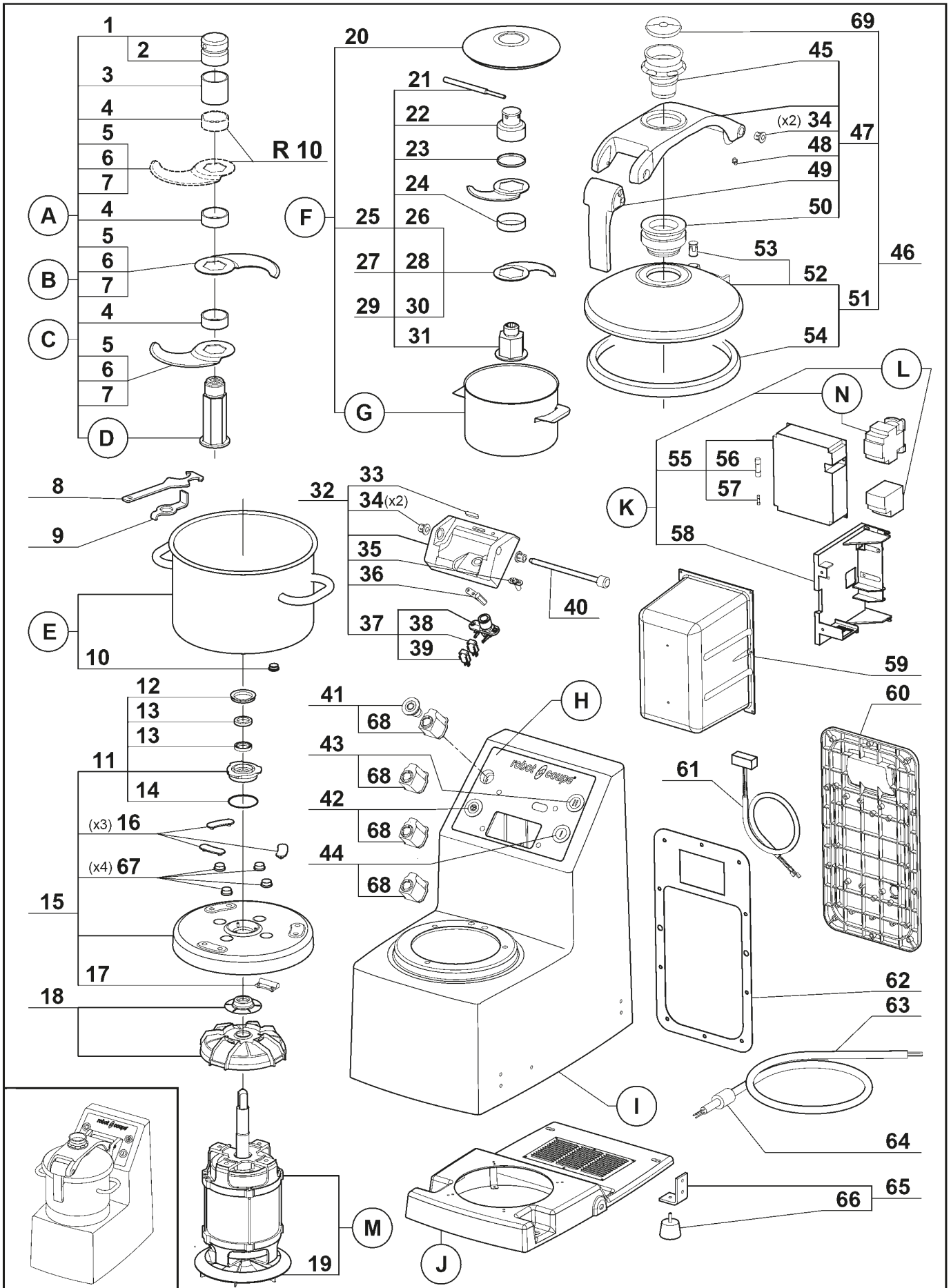

Index	Pièce / Part	Désignation	Description
1	59 278	ECROU DE COUTEAU	BLADE LOCKING NUT
2	59 279	BAGUE COUTEAU PLASTIQUE 15 MM	PLASTIC RING 15 MM
3	117 225S	BAGUE INOX 45 MM	STAINLESS STEEL 45 MM RING
4	100 792S	BAGUE INOX 15 MM	STAINLESS STEEL 15 MM RING
5	59 280	LAME LISSE	STRAIGHT BALDE
6	59 281	LAME CRANTÉE	COARSE SERRATED BLADE
7	59 282	LAME DENTÉE	FINE SERRATED BLADE
8	119 200S	CLEF DEMONTE COUTEAU	KNIFE WRENCH
9	59 291	DEMONTE COUTEAU	KNIFE TOOL
10	59 292	AIMANT CUVE	BOWL MAGNET
11	59 293	DOUILLE PORTE JOINTS	SEALING SOCKET
12	500 901S	JOINT V RING	V RING
13	501 624S	BAGUE ETANCHEITE	LIP SEAL
14	502 670S	JOINT TORIQUE	O RING
15	59 294	SUPPORT MOTEUR	MOTOR SUPPORT
16	59 299	APPUI CUVE (X3)	BOWL REST (X3)
17	59 300	SECURITE CUVE	BOWL SECURITY
18	59 310	DÉFLECTEUR ET GUIDE D'EAU	DEFLECTOR AND WATER PROTECTOR
19	59 311	VENTILATEUR	MOTOR FAN
20	59 457	COUVERCLE MINI CUVE	MINI BOWL LID
21	101 845S	CLEF COUTEAU MINI CUVE	MINI BOWL BLADE TOOL
22	101 804S	ECROU COUT MINI CUVE	MINI BLADE ASSY KNOB
23	101 846S	RONDELLE E4 COUT MINI CUVE	MINI BOWL 4 MM SPACER
24	101 806S	BAGUE 15 MM MINI CUVE	MINI BOWL 15 MM SPACER
25	59 458	COUTEAU MINI CUVE	MINI BOWL STRAIGHT BLADE ASSY
26	101 800S	LAME LISSE MINI CUVE	MINI BOWL STRAIGHT BLADE
27	59 460	COUTEAU DENTE MINI CUVE	MINI BOWL F SERRATED BLADE ASSY
28	59 436	LAME DENTEE MINI CUVE	MINI BOWL FINE SERRATED BLADE
29	59 459	COUTEAU CRANTE MINI CUVE	MINI BOWL C SERRATED BLADE ASSY
30	101 801S	LAME CRANTEE MINI CUVE	MINI BOWL COARSE SERRATED BLADE
31	101 802S	SUPPORT MINI COUTEAU	MINI BOWL KNIFE ASSY SUPPORT
32	59 328	ENS CHARNIÈRE	HINGE ASSEMBLY
33	59 329	BUTÉE DE BRAS	LID ARM REST
34	59 315	DOUILLE DE CENTRAGE	CENTERING WASHER
35	59 330	VOYANT	LIGHT
36	59 331	SÉCURITÉ COUVERCLE	LID SECURITY
37	59 332	SECURITÉ DE BRAS	LID SUPPORT SECURITY
38	501 258S	INTERRUPTEUR SECURITE	SECURITY SWITCH
39	507 250S	INTERRUPTEUR SECURITE	SECURITY SWITCH
40	59 333	AXE CHARNIÈRE	HINGE PIN
41	59 484	BOUTON ARRÊT	STOP BUTON
42	59 487	BOUTON PULSE	PULSE BUTON
43	59 486	BOUTON II	II BUTON
44	59 485	BOUTON I	I BUTON
45	59 313	CONE DE COUVERCLE	LID FUNNEL
46	59 314	ENS BRAS ET COUVERCLE	LID AND ARM ASSEMBLY
47	59 388	SUPPORT COUVERCLE	LID SUPPORT
48	59 316	DOIGT DE SÉCRUITÉ	SECURITY PISTON
49	59 317	ENSEMBLE POIGNÉE	LID HANDLE ASSEMBLY
50	59 318	APPUI DE COUVERCLE	LID GUIDE
51	59 319	ENSEMBLE COUVERCLE	LID ASSEMBLY
52	59 320	COUVERCLE	LID
53	59 321	ENSEMBLE AIMANT COUVERCLE	LID MAGNET ASSEMBLY
54	59 322	JOINT DE COUVERCLE	LID GASKET
55	59 335	CARTE DE COMMANDE	PCB
56	502 495S	FUSIBLE 10X38	10X38 FUSE
57	502 442S	FUSIBLE 5X20	5X20 FUSE
58	59 339	SUPPORT CARTE	PCB SUPPORT
59	59 337	PROTECTION CARTE	PCB PROTECTION
60	59 338	TRAPPE	FLAP DOOR
61	59 336	FAISCEAU DE CONNEXION	CONNECTION WIRES
62	59 340	JOINT TRAPPE ACCES	FLAP DOOR SEAL
63	59 341	CABLE	POWER CORD
64	501 773S	PASSE-FIL	WIRE DUCK
65	59 342	PIED COMPLET	FOOT ASSEMBLY
66	100 790S	PIED	FOOT
67	59 453	ENSEMBLE CACHE-VIS (X4)	MOTOR BOLT CUP KIT (X4)
68	59 007	CONTACT PROTÉGÉ	PROTECTED SWITCH
69	59 009	BOUCHON COUVERCLE	LID CAP

Index	Désignation	Description
<b>A</b>	ENS COUTEAU LAMES LISSES	STRAIGHT BALDE ASSEMBLY
<b>B</b>	ENS COUTEAU LAMES CRANTÉES	COARSE SERRATED BLADE ASSEMBLY
<b>C</b>	ENS COUTEAU LAMES DENTÉES	FINE SERRATED BLADE ASSEMBLY
<b>D</b>	SUPPORT COUTEAU	BLADE SUPPORT
<b>E</b>	CUVE	BOWL
<b>F</b>	ENSEMBLE MINI CUVE	MINI BOWL ASSEMBLY
<b>G</b>	MINI CUVE	MINI BOWL
<b>H</b>	PLAQUE FRONTALE	FRONT PLATE
<b>I</b>	SOCLE	BASE ASSEMBLY
<b>J</b>	GUIDE D'AIR	AIR DEFLECTOR
<b>K</b>	ENSEMBLE DE COMMANDE	COMMAND ESSEMBLY
<b>L</b>	RELAIS THERMIQUE	THERMAL RELAY
<b>M</b>	MOTEUR	MOTOR
<b>N</b>	CONTACTEUR	CONTACTOR

Type	Machine	Voltage	A	B	C	D	E
<b>R8</b> - 512 - - - - -	<b>TOUTES ALL</b>	<b>TOUS ALL</b>	<b>27 381</b>	<b>27 383</b>	<b>27 385</b>	<b>101 636S</b>	<b>59 264</b>
	Machine	Voltage	F	G	H	I	J
	<b>TOUTES ALL</b>	<b>TOUS ALL</b>	<b>27 374</b>	<b>59 430</b>	<b>59 343</b>	<b>59 344</b>	<b>59 346</b>
	Machine	Voltage	K	L	M	N	
	<b>21 291</b>	<b>400/50/3</b>	<b>59 404</b>	<b>59 349</b>	<b>59 351</b>	<b>59 347</b>	
	<b>21 293</b>	<b>220/60/3</b>	<b>59 463</b>	<b>59 350</b>	<b>59 352</b>	<b>59 348</b>	
	<b>21 294</b>	<b>380/60/3</b>	<b>59 404</b>	<b>59 349</b>		<b>59 347</b>	
	<b>21 295</b>	<b>230/50/3</b>	<b>59 463</b>	<b>59 350</b>	<b>59 351</b>	<b>59 348</b>	
<b>21 296</b>	<b>200/60/3</b>	<b>59 352</b>					

Type	Machine	Voltage	A	B	C	D	E
<b>R10</b> - 514 - - - - -	<b>TOUTES ALL</b>	<b>TOUS ALL</b>	<b>27 382</b>	<b>27 384</b>	<b>27 386</b>	<b>101 967S</b>	<b>59265</b>
	Machine	Voltage	F	G	H	I	J
	<b>TOUTES ALL</b>	<b>TOUS ALL</b>	<b>27 375</b>	<b>59 435</b>	<b>59 353</b>	<b>59 354</b>	<b>59 355</b>
	Machine	Voltage	K	L	M	N	
	<b>21 391</b>	<b>400/50/3</b>	<b>59 404</b>	<b>59 349</b>	<b>59 357</b>	<b>59 347</b>	
	<b>21 393</b>	<b>220/60/3</b>	<b>59 463</b>	<b>59 350</b>	<b>59 358</b>	<b>59 348</b>	
	<b>21 394</b>	<b>380/60/3</b>	<b>59 404</b>	<b>59 349</b>		<b>59 347</b>	
	<b>21 395</b>	<b>230/50/3</b>	<b>59 463</b>	<b>59 350</b>	<b>59 357</b>	<b>59 348</b>	
<b>21 396</b>	<b>200/60/3</b>	<b>59 358</b>					

**robotcoupe®**

**R15E - R20E**

N° de série / Serial number

- 516 - - - - -

- 518 - - - - -

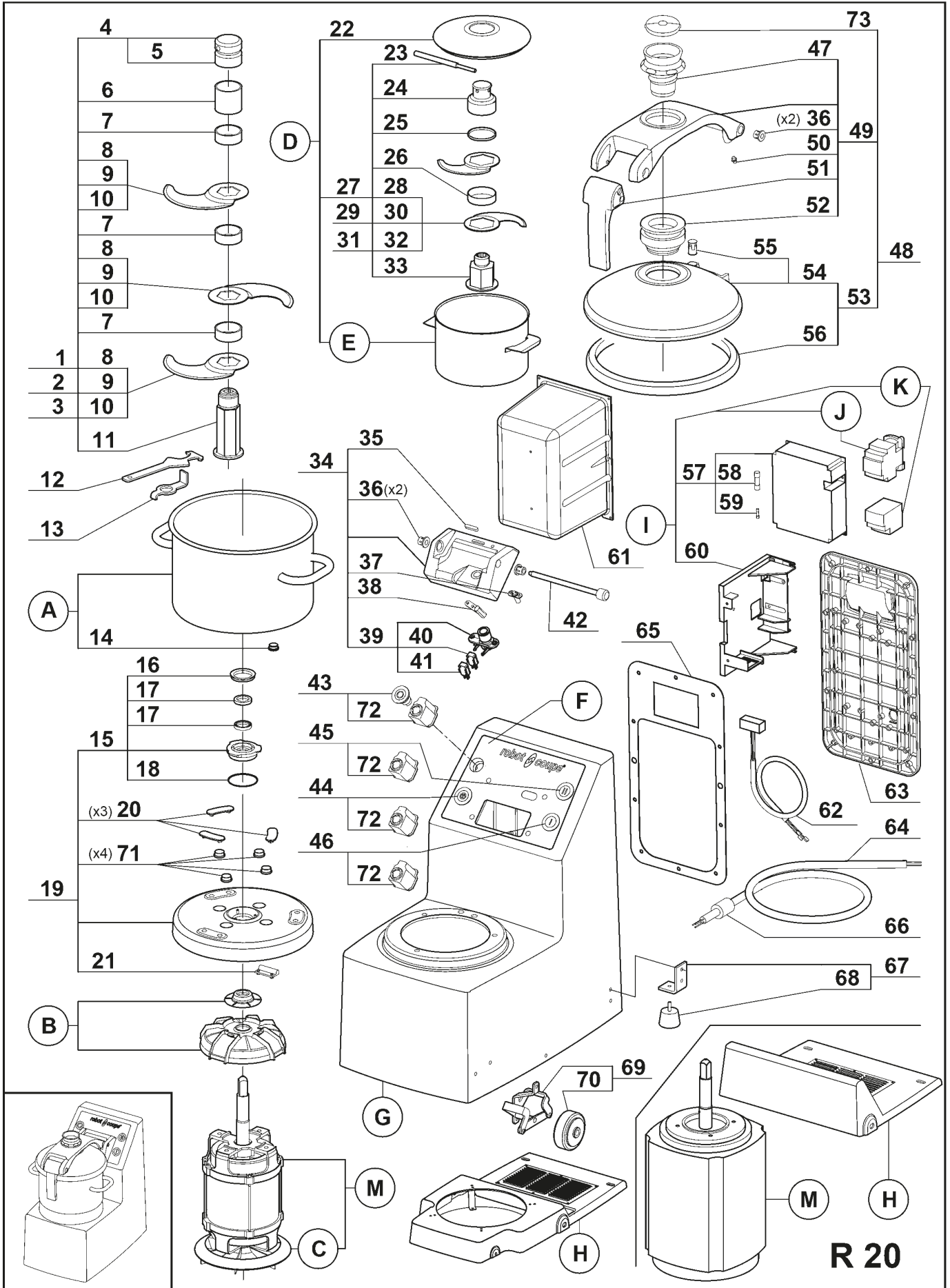

**R 20**

Index	Pièce / Part	Désignation	Description
1	57 097	ENS COUTEAU LAMES LISSES	STRAIGHT BALDE ASSEMBLY
2	57 098	ENS COUTEAU LAMES CRANTÉES	COARSE SERRATED BLADE ASSEMBLY
3	57 099	ENS COUTEAU LAMES DENTÉES	FINE SERRATED BLADE ASSEMBLY
4	59 278	ECROU DE COUTEAU	BLADE LOCKING NUT
5	59 279	BAGUE COUTEAU PLASTIQUE 15 MM	PLASTIC RING 15 MM
6	117 225S	BAGUE INOX 45 MM	STAINLESS STEEL 45 MM RING
7	100 792S	BAGUE INOX 15 MM	STAINLESS STEEL 15 MM RING
8	59 392	LAME LISSE	STRAIGHT BALDE
9	59 393	LAME CRANTÉE	COARSE SERRATED BLADE
10	59 359	LAME DENTÉE	FINE SERRATED BLADE
11	101 967S	SUPPORT COUTEAU	BLADE SUPPORT
12	119 200S	CLEF DEMONTE COUTEAU	KNIFE WRENCH
13	59 291	DEMONTE COUTEAU	KNIFE TOOL
14	59 292	AIMANT CUVE	BOWL MAGNET
15	59 293	DOUILLE PORTE JOINT	SEALING SOCKET
16	500 901S	JOINT V RING	V RING
17	501 624S	BAGUE ETANCHEITE	LIP SEAL
18	502 670S	JOINT TORIQUE	O RING
19	59 360	SUPPORT MOTEUR	MOTOR SUPPORT
20	59 299	APPUI CUVE (X3)	BOWL REST (X3)
21	59 300	SECURITE CUVE	BOWL SECURITY
22	59 457	COUVERCLE MINI CUVE	MINI BOWL LID
23	101 845S	CLEF COUTEAU MINI CUVE	MINI BOWL BLADE TOOL
24	101 804S	ECROU COUT MINI CUVE	MINI BOWL ASSY KNOB
25	101 846S	RONDELLE E4 COUT MINI CUVE	MINI BOWL 4MM SPACER
26	101 806S	BAGUE 15MM MINI CUVE	MINI BOWL 15MM SPACER
27	59 458	COUTEAU MINI CUVE	MINI BOWL STRAIGHT BLADE ASSY
28	101 800S	LAME LISSE MINI CUVE	MINI BOWL STRAIGHT BLADE
29	59 460	COUTEAU DENTE MINI CUVE	MINI BOWL F SERRATED BLADE ASSY
30	59 436	LAME DENTEE MINI CUVE	MINI BOWL FINE SERRATED BLADE
31	59 459	COUTEAU CRANTE MINI CUVE	MINI BOWL C SERRATED BLADE ASSY
32	101 801S	LAME CRANTEE MINI CUVE	MINI BOWL COARSE SERRATED BLADE
33	101 802S	SUPPORT MINI COUTEAU	MINI BOWL KNIFE ASSY SUPPORT
34	59 328	ENS CHARNIÈRE	HINGE ASSEMBLY
35	59 329	BUTÉE DE BRAS	LID ARM REST
36	59 315	DOUILLE DE CENTRAGE	CENTERING WASHER
37	59 330	VOYANT	LIGHT
38	59 331	SÉCURITÉ COUVERCLE	LID SECURITY
39	59 332	SECURITÉ DE BRAS	LID SUPPORT SECURITY
40	501 258S	INTERRUPTEUR SECURITE	SECURITY SWITCH
41	507 250S	INTERRUPTEUR SECURITE	SECURITY SWITCH
42	59 333	AXE CHARNIÈRE	HINGE PIN
43	59 484	BOUTON ARRÊT	STOP BUTON
44	59 487	BOUTON PULSE	PULSE BUTON
45	59 486	BOUTON II	II BUTON
46	59 485	BOUTON I	I BUTON
47	59 313	CONE DE COUVERCLE	LID FUNNEL
48	59 361	ENS BRAS ET COUVERCLE	LID AND ARM ASSEMBLY
49	59 389	SUPPORT COUVERCLE	LID SUPPORT
50	59 316	DOIGT DE SÉCRUITÉ	SECURITY PISTON
51	59 317	ENSEMBLE POIGNÉE	LID HANDLE ASSEMBLY
52	59 318	APPUI DE COUVERCLE	LID GUIDE
53	59 362	ENSEMBLE COUVERCLE	LID ASSEMBLY
54	59 363	COUVERCLE	LID
55	59 321	ENSEMBLE AIMANT COUVERCLE	LID MAGNET ASSEMBLY
56	59 364	JOINT DE COUVERCLE	LID GASKET
57	59 335	CARTE DE COMMANDE	PCB
58	502 495S	FUSIBLE 10X38	10X38 FUSE
59	502 442S	FUSIBLE 5X20	5X20 FUSE
60	59 339	SUPPORT CARTE	PCB SUPPORT
61	59 337	PROTECTION CARTE	PCB PROTECTION
62	59 336	FAISCEAU DE CONNEXION	CONNECTION WIRES
63	59 338	TRAPPE	FLAP DOOR



Index	Pièce / Part	Désignation	Description
64	<b>59 341</b>	CABLE	POWER CORD
65	<b>59 340</b>	JOINT TRAPPE ACCES	FLAP DOOR SEAL
66	<b>501 773S</b>	PASSE-FIL	WIRE DUCK
67	<b>59 342</b>	PIED COMPLET	FOOT ASSEMBLY
68	<b>100 790S</b>	PIED	FOOT
69	<b>59 365</b>	ENSEMBLE ROULETTE	CASTOR ASSEMBLY
70	<b>500 551S</b>	ROULETTE	CASTOR
71	<b>59 453</b>	ENSEMBLE CACHE-VIS (X4)	MOTOR BOLT CUP KIT (X4)
72	<b>59 007</b>	CONTACT PROTÉGÉ	PROTECTED SWITCH
73	<b>59 009</b>	BOUCHON COUVERCLE	LID CAP

Index	Désignation	Description
<b>A</b>	CUVE	BOWL
<b>B</b>	DEFLECTEUR ET GUIDE D'EAU	DEFLECTOR AND WATER PROTECTION
<b>C</b>	VENTILATEUR	MOTOR FAN
<b>D</b>	ENSEMBLE MINI CUVE	MINI BOWL ASSY
<b>E</b>	MINI CUVE	MINIBOWL
<b>F</b>	PLAQUE FRONTALE	FRONT PLATE
<b>G</b>	SOCLE	BASE ASSEMBLY
<b>H</b>	GUIDE D'AIR	AIR DEFLECTOR
<b>I</b>	ENSEMBLE DE COMMANDE	COMMAND ASSEMBLY
<b>J</b>	CONTACTEUR	CONTACTOR
<b>K</b>	RELAIS THERMIQUE	THERMAL RELAY
<b>M</b>	MOTEUR	MOTOR

Type	Machine	Voltage	A	B	C	D	E
<b>R15</b> - 516 - - - - -	<b>TOUTES ALL</b>	<b>TOUS ALL</b>	<b>59 266</b>	<b>59 310</b>	<b>59 311</b>	<b>27 375</b>	<b>59 435</b>
	<b>Machine</b>	<b>Voltage</b>	<b>F</b>	<b>G</b>	<b>H</b>		
	<b>TOUTES ALL</b>	<b>TOUS ALL</b>	<b>59 366</b>	<b>59 368</b>	<b>59 369</b>		
	<b>Machine</b>	<b>Voltage</b>	<b>I</b>	<b>J</b>	<b>K</b>	<b>M</b>	
	<b>51 491</b>	<b>400/50/3</b>	<b>59 404</b>	<b>59 347</b>	<b>59 349</b>	<b>59 370</b>	
	<b>51 493</b>	<b>220/60/3</b>	<b>59 463</b>	<b>59 348</b>	<b>59 350</b>	<b>59 371</b>	
	<b>51 494</b>	<b>380/60/3</b>	<b>59 404</b>	<b>59 347</b>	<b>59 349</b>		
	<b>51 495</b>	<b>230/50/3</b>	<b>59 463</b>	<b>59 348</b>	<b>59 350</b>	<b>59 370</b>	
	<b>51 496</b>	<b>200/60/3</b>				<b>59 371</b>	

Type	Machine	Voltage	A	B	C	D	E
<b>R20</b> - 518 - - - - -	<b>TOUTES ALL</b>	<b>TOUS ALL</b>	<b>59 267</b>	-	-	-	-
	<b>Machine</b>	<b>Voltage</b>	<b>F</b>	<b>G</b>	<b>H</b>		
	<b>TOUTES ALL</b>	<b>TOUS ALL</b>	<b>59 372</b>	<b>59 373</b>	<b>59 374</b>		
	<b>Machine</b>	<b>Voltage</b>	<b>I</b>	<b>J</b>	<b>K</b>	<b>M</b>	
	<b>51 591</b>	<b>400/50/3</b>	<b>59 406</b>	<b>59 375</b>	<b>59 350</b>	<b>59 377</b>	
	<b>51 593</b>	<b>220/60/3</b>	<b>59 405</b>	<b>59 376</b>	<b>59 380</b>	<b>59 379</b>	
	<b>51 594</b>	<b>380/60/3</b>	<b>59 406</b>	<b>59 375</b>	<b>59 350</b>		
	<b>51 595</b>	<b>230/50/3</b>	<b>59 405</b>	<b>59 376</b>	<b>59 380</b>	<b>59 377</b>	
	<b>51 596</b>	<b>200/60/3</b>				<b>59 379</b>	

**robotcoupe®**

**R8E V.V. - R10E V.V.**

N° de série / Serial number

- 513 - - - - -

- 515 - - - - -

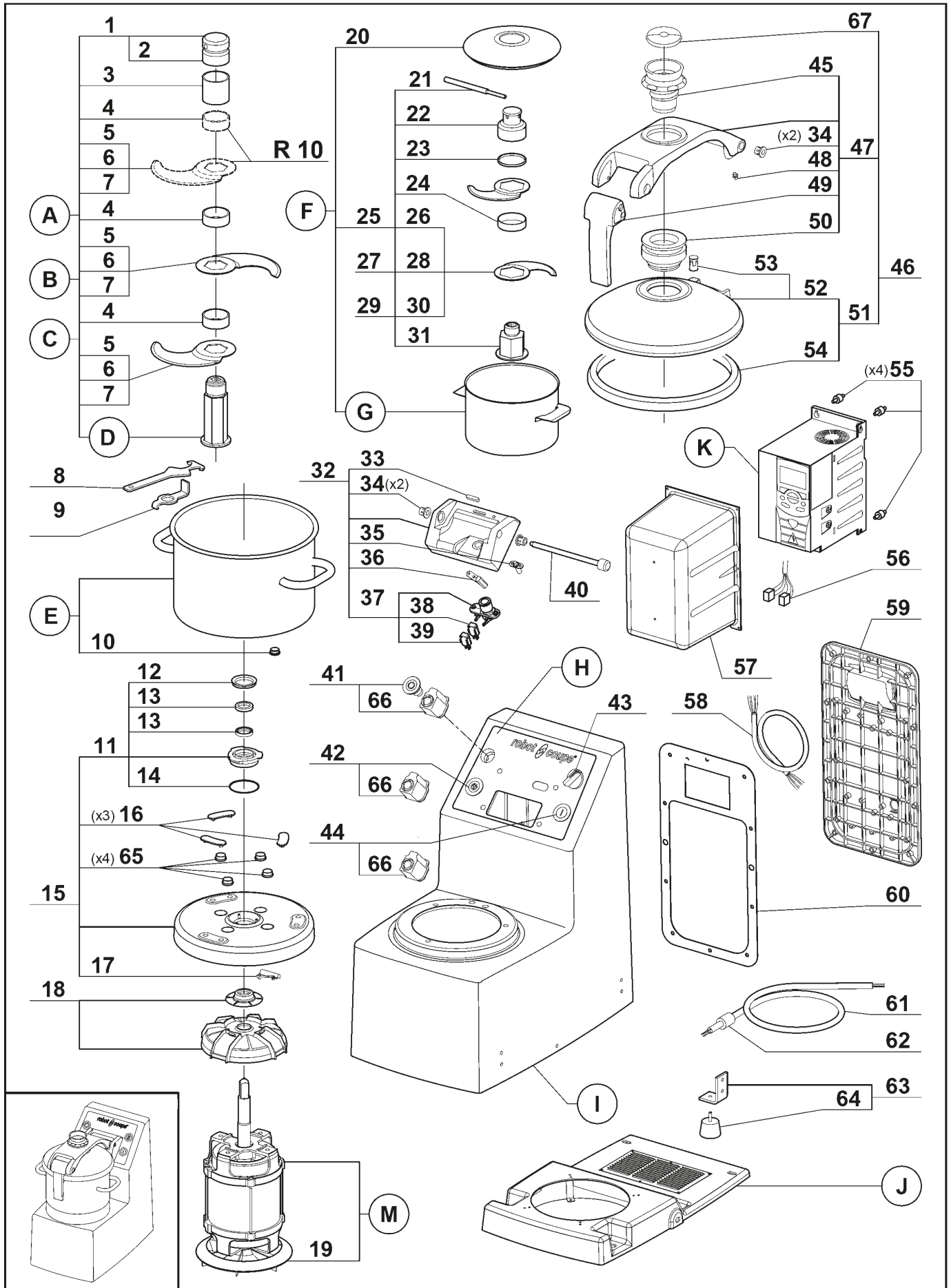

Index	Pièce / Part	Désignation	Description
1	59 278	ECROU DE COUTEAU	BLADE LOCKING NUT
2	59 279	BAGUE COUTEAU PLASTIQUE 15 MM	PLASTIC RING 15 MM
3	117 225S	BAGUE INOX 45 MM	STAINLESS STEEL 45 MM RING
4	100 792S	BAGUE INOX 15 MM	STAINLESS STEEL 15 MM RING
5	59 280	LAME LISSE	STRAIGHT BALDE
6	59 281	LAME CRANTÉE	COARSE SERRATED BLADE
7	59 282	LAME DENTÉE	FINE SERRATED BLADE
8	119 200S	CLEF DEMONTE COUTEAU	KNIFE WRENCH
9	59 291	DEMONTE COUTEAU	KNIFE TOOL
10	59 292	AIMANT CUVE	BOWL MAGNET
11	59 293	DOUILLE PORTE JOINTS	SEALING SOCKET
12	500 901S	JOINT V RING	V RING
13	501 624S	BAGUE ETANCHEITE	LIP SEAL
14	502 670S	JOINT TORIQUE	O RING
15	59 294	SUPPORT MOTEUR	MOTOR SUPPORT
16	59 299	APPUI CUVE (X3)	BOWL REST (X3)
17	59 300	SECURITE CUVE	BOWL SECURITY
18	59 310	DÉFLECTEUR ET GUIDE D'EAU	DEFLECTOR AND WATER PROTECTOR
19	59 311	VENTILATEUR	MOTOR FAN
20	59 457	COUVERCLE MINI CUVE	MINI BOWL LID
21	101 845S	CLEF COUTEAU MINI CUVE	MINI BOWL BLADE TOOL
22	101 804S	ECROU COUT MINI CUVE	MINI BLADE ASSY KNOB
23	101 846S	RONDELLE E4 COUT MINI CUVE	MINI BOWL 4 MM SPACER
24	101 806S	BAGUE 15 MM MINI CUVE	MINI BOWL 15 MM SPACER
25	59 458	COUTEAU MINI CUVE	MINI BOWL STRAIGHT BLADE ASSY
26	101 800S	LAME LISSE MINI CUVE	MINI BOWL STRAIGHT BLADE
27	59 460	COUTEAU DENTE MINI CUVE	MINI BOWL F SERRATED BLADE ASSY
28	59 436	LAME DENTEE MINI CUVE	MINI BOWL FINE SERRATED BLADE
29	59 459	COUTEAU CRANTE MINI CUVE	MINI BOWL C SERRATED BLADE ASSY
30	101 801S	LAME CRANTEE MINI CUVE	MINI BOWL COARSE SERRATED BLADE
31	101 802S	SUPPORT MINI COUTEAU	MINI BOWL KNIFE ASSY SUPPORT
32	59 328	ENS CHARNIÈRE	HINGE ASSEMBLY
33	59 329	BUTÉE DE BRAS	LID ARM REST
34	59 315	DOUILLE DE CENTRAGE	CENTERING WASHER
35	59 330	VOYANT	LIGHT
36	59 331	SÉCURITÉ COUVERCLE	LID SECURITY
37	59 332	SECURITÉ DE BRAS	LID SUPPORT SECURITY
38	501 258S	INTERRUPTEUR SECURITE	SECURITY SWITCH
39	507 250S	INTERRUPTEUR SECURITE	SECURITY SWITCH
40	59 333	AXE CHARNIÈRE	HINGE PIN
41	59 484	BOUTON ARRÊT	STOP BUTON
42	59 487	BOUTON PULSE	PULSE BUTON
43	59 001	BOUTON POTENTIOMETRE	POTENTIOMETER BUTON
44	59 485	BOUTON I	I BUTON
45	59 313	CONE DE COUVERCLE	LID FUNNEL
46	59 314	ENS BRAS ET COUVERCLE	LID AND ARM ASSEMBLY
47	59 388	SUPPORT COUVERCLE	LID SUPPORT
48	59 316	DOIGT DE SÉCRUITÉ	SECURITY PISTON
49	59 317	ENSEMBLE POIGNÉE	LID HANDLE ASSEMBLY
50	59 318	APPUI DE COUVERCLE	LID GUIDE
51	59 319	ENSEMBLE COUVERCLE	LID ASSEMBLY
52	59 320	COUVERCLE	LID
53	59 321	ENSEMBLE AIMANT COUVERCLE	LID MAGNET ASSEMBLY
54	59 322	JOINT DE COUVERCLE	LID GASKET
55	59 408	PLOTS (X4)	STUDS (X4)
56	59 410	FAISCEAU MOTEUR	MOTOR WIRES
57	59 337	PROTECTION CARTE	PCB PROTECTION
58	59 407	FAISCEAU V.V.	V.V. WIRES
59	59 427	TRAPPE V.V.	V.V. FLAP DOOR
60	59 340	JOINT TRAPPE ACCES	FLAP DOOR SEAL
61	59 462	CABLE	POWER CORD
62	501 773S	PASSE-FIL	WIRE DUCK
63	59 342	PIED COMPLET	FOOT ASSEMBLY
64	100 790S	PIED	FOOT
65	59 453	ENSEMBLE CACHE-VIS (X4)	MOTOR BOLT CUP KIT (X4)
66	59 007	CONTACT PROTÉGÉ	PROTECTED SWITCH
67	59 009	BOUCHON COUVERCLE	LID CAP

Index	Désignation	Description
<b>A</b>	ENS COUTEAU LAMES LISSES	STRAIGHT BALDE ASSEMBLY
<b>B</b>	ENS COUTEAU LAMES CRANTÉES	COARSE SERRATED BLADE ASSEMBLY
<b>C</b>	ENS COUTEAU LAMES DENTÉES	FINE SERRATED BLADE ASSEMBLY
<b>D</b>	BAGUE COUTEAU LONGUE	LONG RING
<b>E</b>	CUVE	BOWL
<b>F</b>	ENSEMBLE MINI CUVE	MINI BOWL ASSEMBLY
<b>G</b>	MINI CUVE	MINI BOWL
<b>H</b>	PLAQUE FRONTALE	FRONT PLATE
<b>I</b>	SOCLE	BASE ASSEMBLY
<b>J</b>	GUIDE D'AIR	AIR DEFLECTOR
<b>K</b>	VARIATEUR	VARIATOR
<b>M</b>	MOTEUR	MOTOR

Type	Machine	Voltage	A	B	C	D	E	F	G	
<b>R8</b> - 513 -----	<b>TOUTES ALL</b>	<b>TOUS ALL</b>	<b>27 381</b>	<b>27 383</b>	<b>27 385</b>	<b>117 225S</b>	<b>59 264</b>	<b>27 374</b>	<b>59 430</b>	
	<b>Machine</b>	<b>Voltage</b>	<b>H</b>	<b>I</b>	<b>J</b>	<b>M</b>				
	<b>TOUTES ALL</b>	<b>TOUS ALL</b>	<b>59 418</b>	<b>59 344</b>	<b>59 346</b>	<b>59 351</b>				
	<b>Machine</b>	<b>Voltage</b>	<b>K</b>							
	<b>21 285</b>	<b>200-240/1</b>	<b>59 409</b>							
	<b>21 286</b>	<b>200-240/3</b>	<b>59 411</b>							

Type	Machine	Voltage	A	B	C	D	E	F	G	
<b>R10</b> - 515 -----	<b>TOUTES ALL</b>	<b>TOUS ALL</b>	<b>27 382</b>	<b>27 384</b>	<b>27 386</b>	<b>101 195S</b>	<b>59 265</b>	<b>27 375</b>	<b>59 435</b>	
	<b>Machine</b>	<b>Voltage</b>	<b>H</b>	<b>I</b>	<b>J</b>	<b>M</b>				
	<b>TOUTES ALL</b>	<b>TOUS ALL</b>	<b>59 419</b>	<b>59 354</b>	<b>59 355</b>	<b>59 357</b>				
	<b>Machine</b>	<b>Voltage</b>	<b>K</b>							
	<b>21 385</b>	<b>200-240/1</b>	<b>59 412</b>							
	<b>21 386</b>	<b>200-240/3</b>	<b>59 426</b>							

**robotcoupe®**

**R15E V.V. - R20E V.V.**

N° de série / Serial number

- 517 - - - - -

- 519 - - - - -

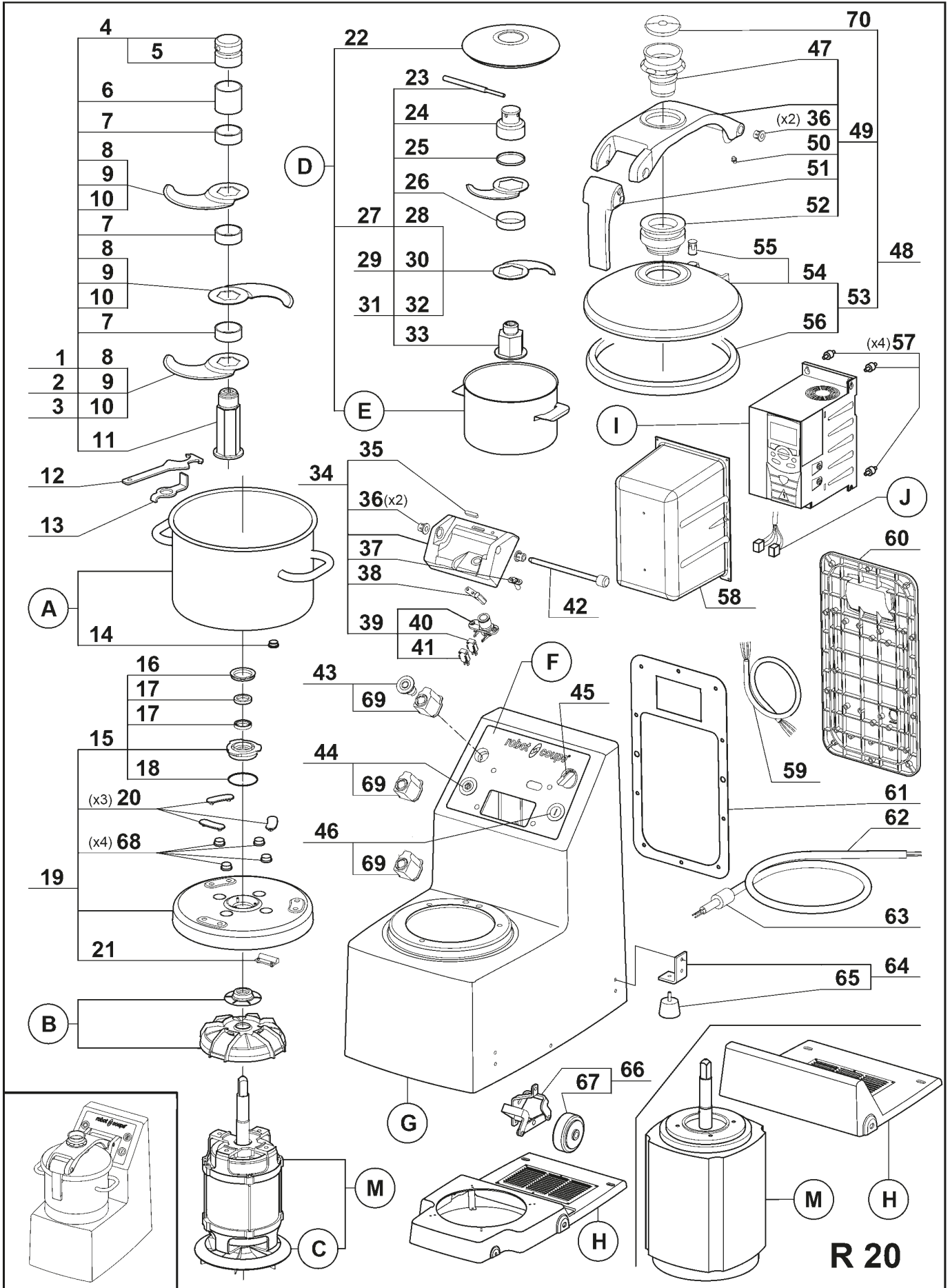

**R 20**

Index	Pièce / Part	Désignation	Description
1	57 097	ENS COUTEAU LAMES LISSES	STRAIGHT BALDE ASSEMBLY
2	57 098	ENS COUTEAU LAMES CRANTÉES	COARSE SERRATED BLADE ASSEMBLY
3	57 099	ENS COUTEAU LAMES DENTÉES	FINE SERRATED BLADE ASSEMBLY
4	59 278	ECROU DE COUTEAU	BLADE LOCKING NUT
5	59 279	BAGUE COUTEAU PLASTIQUE 15 MM	PLASTIC RING 15 MM
6	117 225S	BAGUE INOX 45 MM	STAINLESS STEEL 45 MM RING
7	100 792S	BAGUE INOX 15 MM	STAINLESS STEEL 15 MM RING
8	59 392	LAME LISSE	STRAIGHT BALDE
9	59 393	LAME CRANTÉE	COARSE SERRATED BLADE
10	59 359	LAME DENTÉE	FINE SERRATED BLADE
11	101 967S	SUPPORT COUTEAU	BLADE SUPPORT
12	119 200S	CLEF DEMONTE COUTEAU	KNIFE WRENCH
13	59 291	DEMONTE COUTEAU	KNIFE TOOL
14	59 292	AIMANT CUVE	BOWL MAGNET
15	59 293	DOUILLE PORTE JOINT	SEALING SOCKET
16	500 901S	JOINT V RING	V RING
17	501 624S	BAGUE ETANCHEITE	LIP SEAL
18	502 670S	JOINT TORIQUE	O RING
19	59 360	SUPPORT MOTEUR	MOTOR SUPPORT
20	59 299	APPUI CUVE (X3)	BOWL REST (X3)
21	59 300	SECURITE CUVE	BOWL SECURITY
22	59 457	COUVERCLE MINI CUVE	MINI BOWL LID
23	101 845S	CLEF COUTEAU MINI CUVE	MINI BOWL BLADE TOOL
24	101 804S	ECROU COUT MINI CUVE	MINI BOWL ASSY KNOB
25	101 846S	RONDELLE E4 COUT MINI CUVE	MINI BOWL 4MM SPACER
26	101 806S	BAGUE 15MM MINI CUVE	MINI BOWL 15MM SPACER
27	59 458	COUTEAU MINI CUVE	MINI BOWL STRAIGHT BLADE ASSY
28	101 800S	LAME LISSE MINI CUVE	MINI BOWL STRAIGHT BLADE
29	59 460	COUTEAU DENTE MINI CUVE	MINI BOWL F SERRATED BLADE ASSY
30	59 436	LAME DENTEE MINI CUVE	MINI BOWL FINE SERRATED BLADE
31	59 459	COUTEAU CRANTE MINI CUVE	MINI BOWL C SERRATED BLADE ASSY
32	101 801S	LAME CRANTEE MINI CUVE	MINI BOWL COARSE SERRATED BLADE
33	101 802S	SUPPORT MINI COUTEAU	MINI BOWL KNIFE ASSY SUPPORT
34	59 328	ENS CHARNIÈRE	HINGE ASSEMBLY
35	59 329	BUTÉE DE BRAS	LID ARM REST
36	59 315	DOUILLE DE CENTRAGE	CENTERING WASHER
37	59 330	VOYANT	LIGHT
38	59 331	SÉCURITÉ COUVERCLE	LID SECURITY
39	59 332	SECURITÉ DE BRAS	LID SUPPORT SECURITY
40	501 258S	INTERRUPTEUR SECURITE	SECURITY SWITCH
41	507 250S	INTERRUPTEUR SECURITE	SECURITY SWITCH
42	59 333	AXE CHARNIÈRE	HINGE PIN
43	59 484	BOUTON ARRÊT	STOP BUTON
44	59 487	BOUTON PULSE	PULSE BUTON
45	59 001	BOUTON POTENTIOMETRE	POTENTIOMETER BUTON
46	59 485	BOUTON I	I BUTON
47	59 313	CONE DE COUVERCLE	LID FUNNEL
48	59 361	ENS BRAS ET COUVERCLE	LID AND ARM ASSEMBLY
49	59 389	SUPPORT COUVERCLE	LID SUPPORT
50	59 316	DOIGT DE SÉCRUITÉ	SECURITY PISTON
51	59 317	ENSEMBLE POIGNÉE	LID HANDLE ASSEMBLY
52	59 318	APPUI DE COUVERCLE	LID GUIDE
53	59 362	ENSEMBLE COUVERCLE	LID ASSEMBLY
54	59 363	COUVERCLE	LID
55	59 321	ENSEMBLE AIMANT COUVERCLE	LID MAGNET ASSEMBLY
56	59 364	JOINT DE COUVERCLE	LID GASKET

Index	Pièce / Part	Désignation	Description
57	<b>59 408</b>	PLOTS (X4)	STUDS (X4)
58	<b>59 337</b>	PROTECTION CARTE	PCB PROTECTION
59	<b>59 407</b>	FAISCEAU V.V.	V.V. WIRES
60	<b>59 427</b>	TRAPPE V.V.	V.V. FLAP DOOR
61	<b>59 340</b>	JOINT TRAPPE ACCES	FLAP DOOR SEAL
62	<b>59 341</b>	CABLE	POWER CORD
63	<b>501 773S</b>	PASSE-FIL	WIRE DUCK
64	<b>59 342</b>	PIED COMPLET	FOOT ASSEMBLY
65	<b>100 790S</b>	PIED	FOOT
66	<b>59 365</b>	ENSEMBLE ROULETTE	CASTOR ASSEMBLY
67	<b>500 551S</b>	ROULETTE	CASTOR
68	<b>59 453</b>	ENSEMBLE CACHE-VIS (X4)	MOTOR BOLT CUP KIT (X4)
69	<b>59 007</b>	CONTACT PROTÉGÉ	PROTECTED SWITCH
70	<b>59 009</b>	BOUCHON COUVERCLE	LID CAP

Index	Désignation	Description
<b>A</b>	CUVE	BOWL
<b>B</b>	DEFLECTEUR ET GUIDE D'EAU	DEFLECTOR AND WATER PROTECTION
<b>C</b>	VENTILATEUR	MOTOR FAN
<b>D</b>	ENSEMBLE MINI CUVE	MINI BOWL ASSY
<b>E</b>	MINI CUVE	MINI BOWL
<b>F</b>	PLAQUE FRONTALE	FRONT PLATE
<b>G</b>	SOCLE	BASE ASSEMBLY
<b>H</b>	GUIDE D'AIR	AIR DEFLECTOR
<b>I</b>	VARIATEUR	VARIATOR
<b>J</b>	FAISCEAU MOTEUR	MOTEUR WIRES
<b>M</b>	MOTEUR	MOTOR

Type	Machine	Voltage	A	B	C	D	E	F
<b>R15</b> - 517- - - - -	<b>TOUTES ALL</b>	<b>TOUS ALL</b>	<b>59 266</b>	<b>59 310</b>	<b>59 311</b>	<b>27 375</b>	<b>59 435</b>	<b>59 420</b>
	<b>Machine</b>	<b>Voltage</b>	<b>G</b>	<b>H</b>	<b>M</b>			
	<b>TOUTES ALL</b>	<b>TOUS ALL</b>	<b>59 368</b>	<b>59 369</b>	<b>59 370</b>			
	<b>Machine</b>	<b>Voltage</b>	<b>I</b>	<b>J</b>				
	<b>51 486</b>	<b>200-240/3</b>	<b>59 413</b>	<b>59 410</b>				
	<b>51 487</b>	<b>380-480/3</b>	<b>59 415</b>	<b>59 416</b>				

Type	Machine	Voltage	A	B	C	D	E	F
<b>R20</b> - 519- - - - -	<b>TOUTES ALL</b>	<b>TOUS ALL</b>	<b>59 267</b>	-	-	-	-	<b>59 421</b>
	<b>Machine</b>	<b>Voltage</b>	<b>G</b>	<b>H</b>	<b>M</b>			
	<b>TOUTES ALL</b>	<b>TOUS ALL</b>	<b>59 373</b>	<b>59 374</b>	<b>59 377</b>			
	<b>Machine</b>	<b>Voltage</b>	<b>I</b>	<b>J</b>				
	<b>51 586</b>	<b>200-240/3</b>	<b>59 414</b>	<b>59 410</b>				
	<b>51 587</b>	<b>380-480/3</b>	<b>59 417</b>	<b>59 416</b>				

**robotcoupe®**

**BLIXER® 8E  
BLIXER® 10E**

N° de série / Serial number  
- 528 - - - - -  
- 530 - - - - -

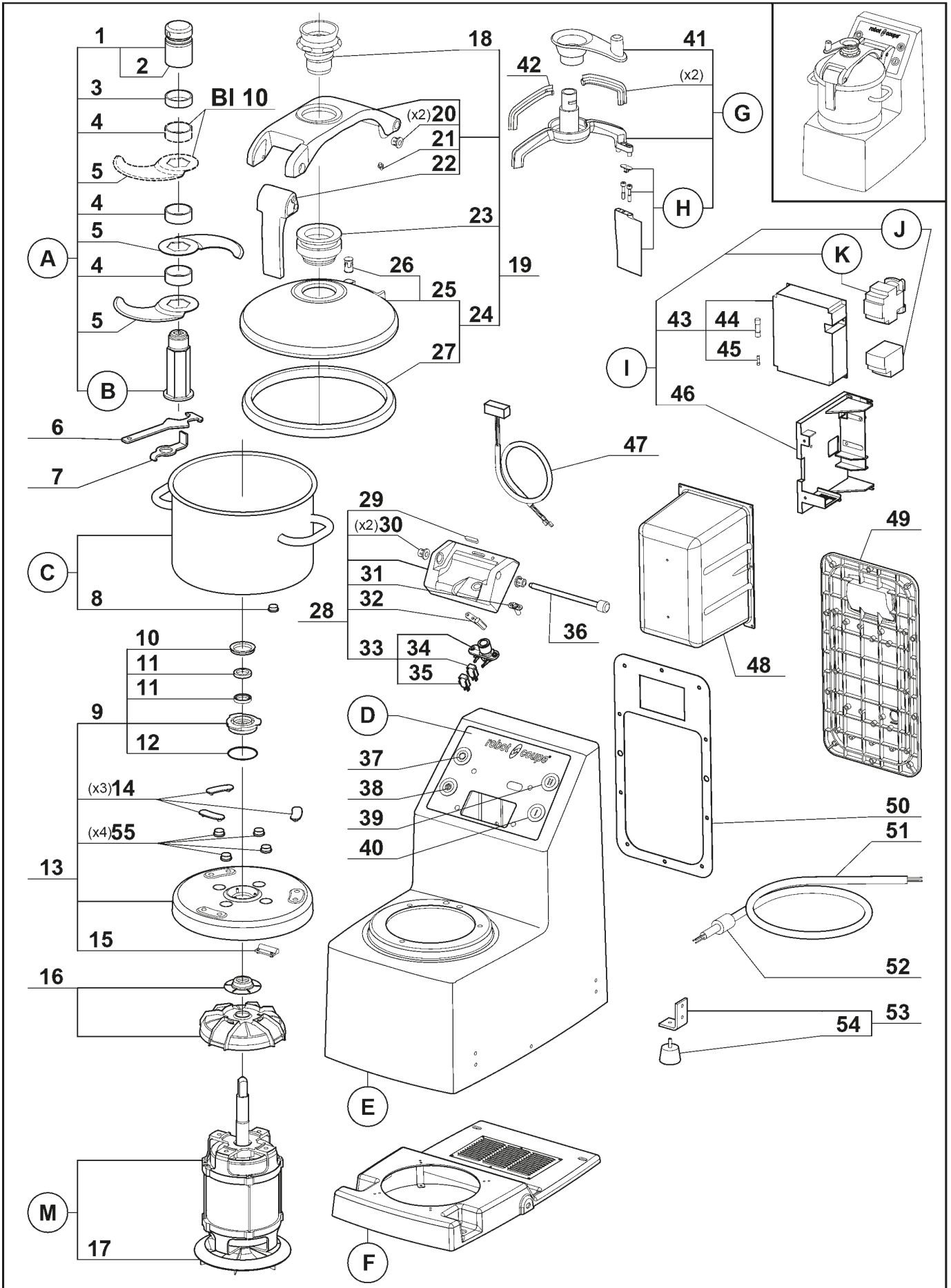



<i>Index</i>	<i>Pièce / Part</i>	<i>Désignation</i>	<i>Description</i>
1	<b>59 396</b>	ECROU DE COUPEAU	BLADE LOCKING NUT
2	<b>117 225S</b>	BAGUE INOX 45 MM	STAINLESS STEEL 45 MM RING
3	<b>59 279</b>	BAGUE COUPEAU PLASTIQUE 15 MM	PLASTIC RING 15 MM
4	<b>100 792S</b>	BAGUE INOX 15 MM	STAINLESS STEEL 15 MM RING
5	<b>59 282</b>	LAME DENTÉE	FINE SERRATED BLADE
6	<b>119 200S</b>	CLEF DEMONTE COUPEAU	KNIFE WRENCH
7	<b>59 291</b>	DEMONTE COUPEAU	KNIFE TOOL
8	<b>59 292</b>	AIMANT CUVE	BOWL MAGNET
9	<b>59 293</b>	DOUILLE PORTE JOINTS	SEALING SOCKET
10	<b>500 901S</b>	JOINT V RING	V RING
11	<b>501 624S</b>	BAGUE ETANCHEITE	LIP SEAL
12	<b>502 670S</b>	JOINT TORIQUE	O RING
13	<b>59 294</b>	SUPPORT MOTEUR	MOTOR SUPPORT
14	<b>59 299</b>	APPUI CUVE (X3)	BOWL REST (X3)
15	<b>59 300</b>	SECURITE CUVE	BOWL SECURITY
16	<b>59 310</b>	DÉFLECTEUR ET GUIDE D'EAU	DEFLECTOR AND WATER PROTECTOR
17	<b>59 311</b>	VENTILATEUR	MOTOR FAN
18	<b>59 313</b>	CONE DE COUVERCLE	LID FUNNEL
19	<b>59 314</b>	ENS BRAS ET COUVERCLE	LID AND ARM ASSEMBLY
20	<b>59 315</b>	DOUILLE DE CENTRAGE (X2)	CENTERING WASHER (X2)
21	<b>59 316</b>	DOIGT DE SÉCRUITÉ	SECURITY PISTON
22	<b>59 317</b>	ENSEMBLE POIGNÉE	LID HANDLE ASSEMBLY
23	<b>59 318</b>	APPUI DE COUVERCLE	LID GUIDE
24	<b>59 319</b>	ENSEMBLE COUVERCLE	LID ASSEMBLY
25	<b>59 320</b>	COUVERCLE	LID
26	<b>59 321</b>	ENSEMBLE AIMANT COUVERCLE	LID MAGNET ASSEMBLY
27	<b>59 322</b>	JOINT DE COUVERCLE	LID GASKET
28	<b>59 328</b>	ENS CHARNIÈRE	HINGE ASSEMBLY
29	<b>59 329</b>	BUTÉE DE BRAS	LID ARM REST
30	<b>59 315</b>	DOUILLE DE CENTRAGE (X2)	CENTERING WASHER (X2)
31	<b>59 330</b>	VOYANT	LIGHT
32	<b>59 331</b>	SÉCURITÉ COUVERCLE	LID SECURITY
33	<b>59 332</b>	SECURITÉ DE BRAS	LID SUPPORT SECURITY
34	<b>501 258S</b>	INTERRUPTEUR SECURITE	SECURITY SWITCH
35	<b>507 250S</b>	INTERRUPTEUR SECURITE	SECURITY SWITCH
36	<b>59 333</b>	AXE CHARNIÈRE	HINGE PIN
37	<b>59 484</b>	BOUTON ARRÊT	STOP BUTON
38	<b>59 487</b>	BOUTON PULSE	PULSE BUTON
39	<b>59 486</b>	BOUTON II	II BUTON
40	<b>59 485</b>	BOUTON I	I BUTON
41	<b>59 395</b>	POIGNEE RACLEUR	BLIXER ARM HANDLE
42	<b>59 390</b>	ENSEMBLE RACLEURS COUVERCLE	LID SCRAPERS ASSEMBLY
43	<b>59 335</b>	CARTE DE COMMANDE	PCB
44	<b>502 495S</b>	FUSIBLE 10X38	10X38 FUSE
45	<b>502 442S</b>	FUSIBLE 5X20	5X20 FUSE
46	<b>59 339</b>	SUPPORT CARTE	PCB SUPPORT
47	<b>59 336</b>	FAISCEAU DE CONNEXION	CONNECTION WIRES
48	<b>59 337</b>	PROTECTION CARTE	PCB PROTECTION
49	<b>59 338</b>	TRAPPE	FLAP DOOR
50	<b>59 340</b>	JOINT TRAPPE ACCES	FLAP DOOR SEAL
51	<b>59 341</b>	CABLE	POWER CORD
52	<b>501 773S</b>	PASSE-FIL	WIRE DUCK
53	<b>59 342</b>	PIED COMPLET	FOOT ASSEMBLY
54	<b>100 790S</b>	PIED	FOOT
55	<b>59 453</b>	ENSEMBLE CACHE-VIS (X4)	MOTOR BOLT CUP KIT (X4)

Index	Désignation	Description
<b>A</b>	ENS COUPEAU LAMES DENTÉES	FINE SERRATED BLADE ASSEMBLY
<b>B</b>	SUPPORT COUPEAU	BLADE SUPPORT
<b>C</b>	CUVE	BOWL
<b>D</b>	PLAQUE FRONTALE	FRONT PLATE
<b>E</b>	SOCLE	BASE ASSEMBLY
<b>F</b>	GUIDE D'AIR	AIR DEFLECTOR
<b>G</b>	ENS. BRAS RACLEUR	SCRAPER ARM ASSEMBLY
<b>H</b>	ENS. RACLEUR CUVE	SCRAPER BOWL ASSEMBLY
<b>I</b>	ENSEMBLE DE COMMANDE	COMMAND ASSEMBLY
<b>J</b>	RELAIS THERMIQUE	THERMAL RELAY
<b>K</b>	CONTACTEUR	CONTACTOR
<b>M</b>	MOTEUR	MOTOR

Type	Machine	Voltage	A	B	C	D	E	F
<b>BLIXER 8</b> - 528 -----	<b>TOUTES ALL</b>	<b>TOUS ALL</b>	<b>27 377</b>	<b>101 636S</b>	<b>59 264</b>	<b>59 398</b>	<b>59 344</b>	<b>59 346</b>
	<b>Machine</b>	<b>Voltage</b>	<b>G</b>	<b>H</b>				
	<b>TOUTES ALL</b>	<b>TOUS ALL</b>	<b>59 381</b>	<b>59 385</b>				
	<b>Machine</b>	<b>Voltage</b>	<b>I</b>	<b>J</b>	<b>K</b>	<b>M</b>		
	<b>21 311</b>	<b>400/50/3</b>	<b>59 404</b>	<b>59 349</b>	<b>59 347</b>	<b>59 351</b>		
	<b>21 313</b>	<b>220/60/3</b>	<b>59 403</b>	<b>59 350</b>	<b>59 348</b>	<b>59 352</b>		
	<b>21 314</b>	<b>380/60/3</b>	<b>59 404</b>	<b>59 349</b>	<b>59 347</b>			
	<b>21 315</b>	<b>230/50/3</b>	<b>59 403</b>	<b>59 350</b>	<b>59 348</b>	<b>59 351</b>		
	<b>21 316</b>	<b>200/60/3</b>				<b>59 352</b>		

Type	Machine	Voltage	A	B	C	D	E	F
<b>BLIXER 10</b> - 530 -----	<b>TOUTES ALL</b>	<b>TOUS ALL</b>	<b>27 378</b>	<b>101 967S</b>	<b>59 265</b>	<b>59 399</b>	<b>59 354</b>	<b>59 355</b>
	<b>Machine</b>	<b>Voltage</b>	<b>G</b>	<b>H</b>				
	<b>TOUTES ALL</b>	<b>TOUS ALL</b>	<b>59 382</b>	<b>59 386</b>				
	<b>Machine</b>	<b>Voltage</b>	<b>I</b>	<b>J</b>	<b>K</b>	<b>M</b>		
	<b>21 411</b>	<b>400/50/3</b>	<b>59 404</b>	<b>59 349</b>	<b>59 347</b>	<b>59 357</b>		
	<b>21 413</b>	<b>220/60/3</b>	<b>59 403</b>	<b>59 350</b>	<b>59 348</b>	<b>59 358</b>		
	<b>21 414</b>	<b>380/60/3</b>	<b>59 404</b>	<b>59 349</b>	<b>59 347</b>			
	<b>21 415</b>	<b>230/50/3</b>	<b>59 403</b>	<b>59 350</b>	<b>59 348</b>	<b>59 357</b>		
	<b>21 416</b>	<b>200/60/3</b>				<b>59 358</b>		

**robotcoupe®**

**BLIXER® 8E V.V.**  
**BLIXER® 10E V.V.**

N° de série / Serial number  
 - 529 - - - - -  
 - 531 - - - - -

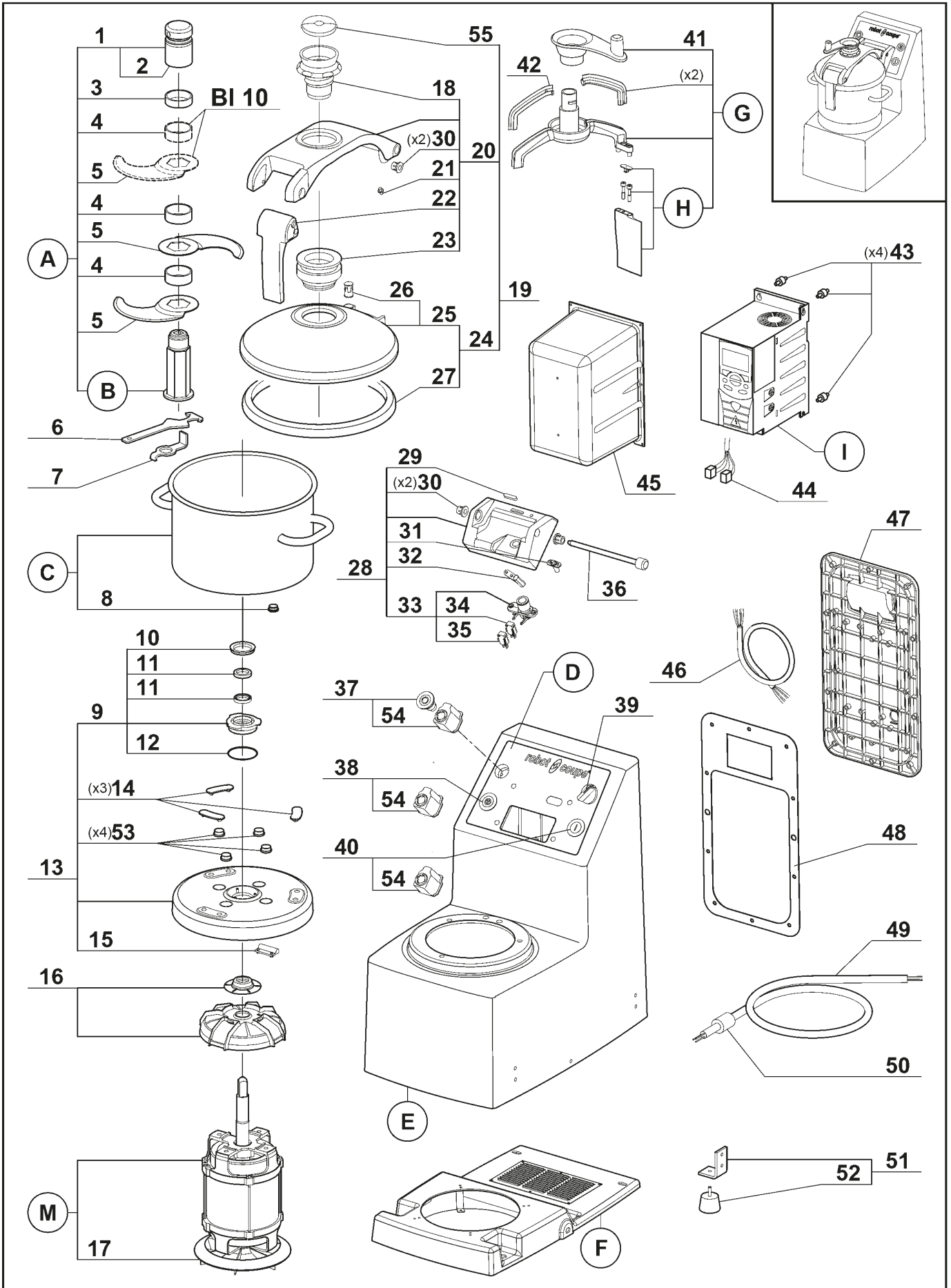

Index	Pièce / Part	Désignation	Description
1	59 396	ECROU DE COUTEAU	BLADE LOCKING NUT
2	117 225S	BAGUE INOX 45 MM	STAINLESS STEEL 45 MM RING
3	59 279	BAGUE COUTEAU PLASTIQUE 15 MM	PLASTIC RING 15 MM
4	100 792S	BAGUE INOX 15 MM	STAINLESS STEEL 15 MM RING
5	59 282	LAME DENTÉE	FINE SERRATED BLADE
6	119 200S	CLEF DEMONTE COUTEAU	KNIFE WRENCH
7	59 291	DEMONTE COUTEAU	KNIFE TOOL
8	59 292	AIMANT CUVE	BOWL MAGNET
9	59 293	DOUILLE PORTE JOINTS	SEALING SOCKET
10	500 901S	JOINT V RING	V RING
11	501 624S	BAGUE ETANCHEITE	LIP SEAL
12	502 670S	JOINT TORIQUE	O RING
13	59 294	SUPPORT MOTEUR	MOTOR SUPPORT
14	59 299	APPUI CUVE (X3)	BOWL REST (X3)
15	59 300	SECURITE CUVE	BOWL SECURITY
16	59 310	DÉFLECTEUR ET GUIDE D'EAU	DEFLECTOR AND WATER PROTECTOR
17	59 311	VENTILATEUR	MOTOR FAN
18	59 313	CONE DE COUVERCLE	LID FUNNEL
19	59 314	ENS BRAS ET COUVERCLE	LID AND ARM ASSEMBLY
20	59 388	SUPPORT COUVERCLE	LID SUPPORT
21	59 316	DOIGT DE SÉCRUITÉ	SECURITY PISTON
22	59 317	ENSEMBLE POIGNÉE	LID HANDLE ASSEMBLY
23	59 318	APPUI DE COUVERCLE	LID GUIDE
24	59 319	ENSEMBLE COUVERCLE	LID ASSEMBLY
25	59 320	COUVERCLE	LID
26	59 321	ENSEMBLE AIMANT COUVERCLE	LID MAGNET ASSEMBLY
27	59 322	JOINT DE COUVERCLE	LID GASKET
28	59 328	ENS CHARNIÈRE	HINGE ASSEMBLY
29	59 329	BUTÉE DE BRAS	LID ARM REST
30	59 315	DOUILLE DE CENTRAGE (X2)	CENTERING WASHER (X2)
31	59 330	VOYANT	LIGHT
32	59 331	SÉCURITÉ COUVERCLE	LID SECURITY
33	59 332	SECURITÉ DE BRAS	LID SUPPORT SECURITY
34	501 258S	INTERRUPTEUR SECURITE	SECURITY SWITCH
35	507 250S	INTERRUPTEUR SECURITE	SECURITY SWITCH
36	59 333	AXE CHARNIÈRE	HINGE PIN
37	59 484	BOUTON ARRÊT	STOP BUTON
38	59 487	BOUTON PULSE	PULSE BUTON
39	59 001	BOUTON POTENTIOMETRE	POTENTIOMETER BUTON
40	59 485	BOUTON I	I BUTON
41	59 395	POIGNEE RACLEUR	BLIXER ARM HANDLE
42	59 390	ENSEMBLE RACLEURS COUVERCLE	LID SCRAPERS ASSEMBLY
43	59 408	PLOTS (X4)	STUDS (X4)
44	59 410	FAISCEAU MOTEUR	MOTOR WIRES
45	59 337	PROTECTION CARTE	PCB PROTECTION
46	59 407	FAISCEAU V.V.	V.V. WIRES
47	59 427	TRAPPE V.V.	V.V. FLAP DOOR
48	59 340	JOINT TRAPPE ACCES	FLAP DOOR SEAL
49	59 462	CABLE	POWER CORD
50	501 773S	PASSE-FIL	WIRE DUCK
51	59 342	PIED COMPLET	FOOT ASSEMBLY
52	100 790S	PIED	FOOT
53	59 453	ENSEMBLE CACHE-VIS (X4)	MOTOR BOLT CUP KIT (X4)
54	59 007	CONTACT PROTÉGÉ	PROTECTED SWITCH
55	59 009	BOUCHON COUVERCLE	LID CAP

Index	Désignation	Description
<b>A</b>	ENS COUTEAU LAMES DENTÉES	FINE SERRATED BLADE ASSEMBLY
<b>B</b>	SUPPORT COUTEAU	BLADE SUPPORT
<b>C</b>	CUVE	BOWL
<b>D</b>	PLAQUE FRONTALE	FRONT PLATE
<b>E</b>	SOCLE	BASE ASSEMBLY
<b>F</b>	GUIDE D'AIR	AIR DEFLECTOR
<b>G</b>	ENS. BRAS RACLEUR	SCRAPER ARM ASSEMBLY
<b>H</b>	ENS. RACLEUR CUVE	SCRAPER BOWL ASSEMBLY
<b>I</b>	VARIATEUR	VARIATOR
<b>M</b>	MOTEUR	MOTOR

Type	Machine	Voltage	A	B	C	D	E	F
<b>BLIXER 8</b> - 529 ----- --	<b>TOUTES ALL</b>	<b>TOUS ALL</b>	<b>27 377</b>	<b>101 636S</b>	<b>59 264</b>	<b>59 422</b>	<b>59 344</b>	<b>59 346</b>
	<b>Machine</b>	<b>Voltage</b>	<b>G</b>	<b>H</b>	<b>M</b>			
	<b>TOUTES ALL</b>	<b>TOUS ALL</b>	<b>59 381</b>	<b>59 385</b>	<b>59 351</b>			
	<b>Machine</b>	<b>Voltage</b>	<b>I</b>					
	<b>21 305</b>	<b>200-240/1</b>	<b>59 409</b>					
	<b>21 306</b>	<b>200-240/3</b>	<b>59 411</b>					

Type	Machine	Voltage	A	B	C	D	E	F
<b>BLIXER 10</b> - 531 ----- --	<b>TOUTES ALL</b>	<b>TOUS ALL</b>	<b>27 378</b>	<b>101 967S</b>	<b>59 265</b>	<b>59 423</b>	<b>59 354</b>	<b>59 355</b>
	<b>Machine</b>	<b>Voltage</b>	<b>G</b>	<b>H</b>	<b>M</b>			
	<b>TOUTES ALL</b>	<b>TOUS ALL</b>	<b>59 382</b>	<b>59 386</b>	<b>59 357</b>			
	<b>Machine</b>	<b>Voltage</b>	<b>I</b>					
	<b>21 405</b>	<b>200-240/1</b>	<b>59 412</b>					
	<b>21 406</b>	<b>200-240/3</b>	<b>59 426</b>					

robotcoupe®

**BLIXER® 15E**  
**BLIXER® 20E**

N° de série / Serial number  
- 532 - - - - -  
- 534 - - - - -

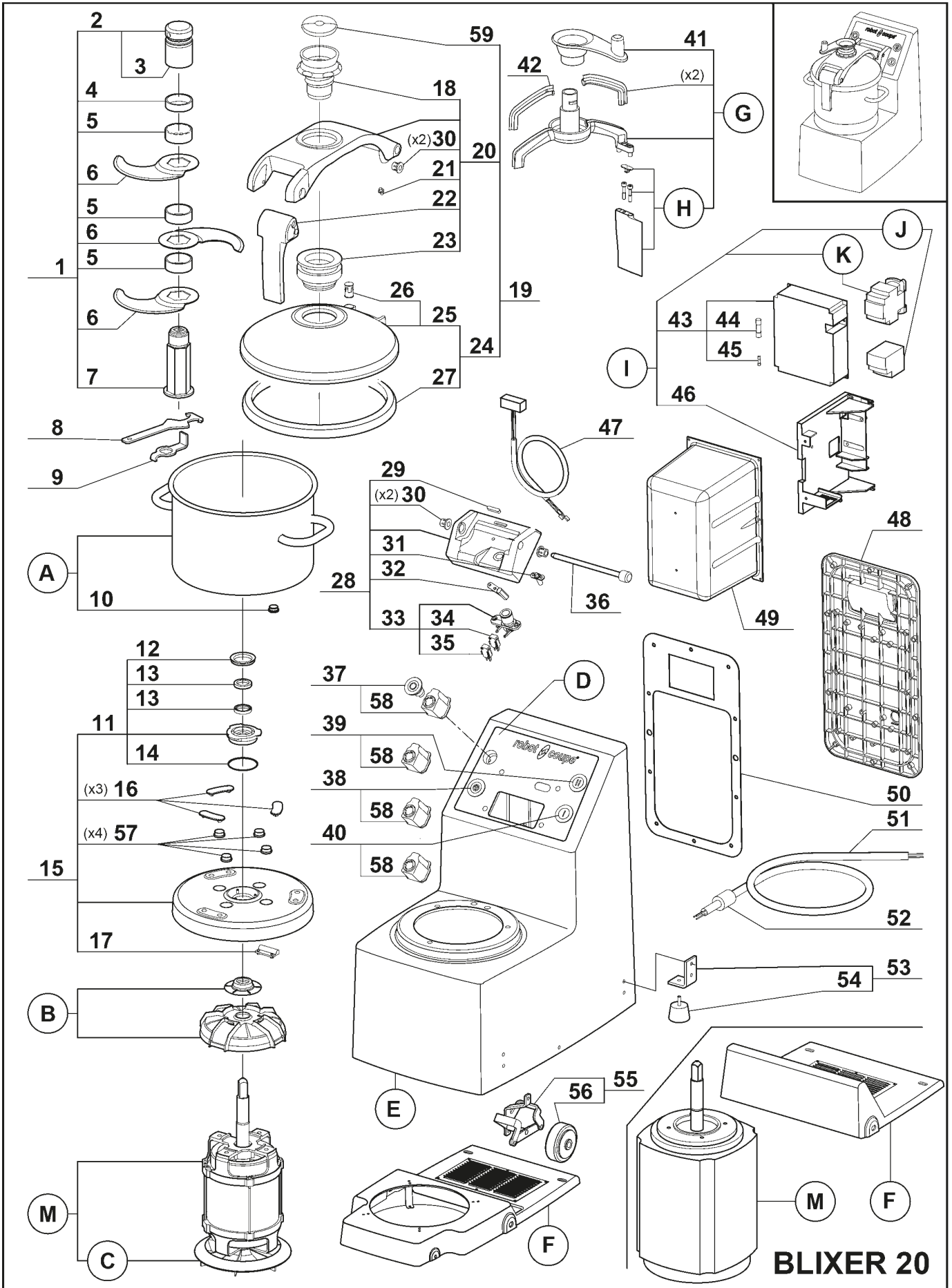

Index	Pièce / Part	Désignation	Description
1	57 102	ENS COUTEAU LAMES DENTÉES	FINE SERRATED BLADE ASSEMBLY
2	59 396	ECROU DE COUTEAU	BLADE LOCKING NUT
3	117 225S	BAGUE INOX 45 MM	STAINLESS STEEL 45 MM RING
4	59 279	BAGUE COUTEAU PLASTIQUE 15 MM	PLASTIC RING 15 MM
5	100 792S	BAGUE INOX 15 MM	STAINLESS STEEL 15 MM RING
6	59 359	LAME DENTÉE	FINE SERRATED BLADE
7	101 967S	SUPPORT COUTEAU	BLADE SUPPORT
8	119 200S	CLEF DEMONTE COUTEAU	KNIFE WRENCH
9	59 291	DEMONTE COUTEAU	KNIFE TOOL
10	59 292	AIMANT CUVE	BOWL MAGNET
11	59 293	DOUILLE PORTE JOINT	SEALING SOCKET
12	500 901S	JOINT V RING	V RING
13	501 624S	BAGUE ETANCHEITE	LIP SEAL
14	502 670S	JOINT TORIQUE	O RING
15	59 360	SUPPORT MOTEUR	MOTOR SUPPORT
16	59 299	APPUI CUVE (X3)	BOWL REST (X3)
17	59 300	SECURITE CUVE	BOWL SECURITY
18	59 313	CONE DE COUVERCLE	LID FUNNEL
19	59 361	ENS BRAS ET COUVERCLE	LID AND ARM ASSEMBLY
20	59 389	SUPPORT COUVERCLE	LID SUPPORT
21	59 316	DOIGT DE SÉCURITÉ	SECURITY PISTON
22	59 317	ENSEMBLE POIGNÉE	LID HANDLE ASSEMBLY
23	59 318	APPUI DE COUVERCLE	LID GUIDE
24	59 362	ENSEMBLE COUVERCLE	LID ASSEMBLY
25	59 363	COUVERCLE	LID
26	59 321	ENSEMBLE AIMANT COUVERCLE	LID MAGNET ASSEMBLY
27	59 364	JOINT DE COUVERCLE	LID GASKET
28	59 328	ENS CHARNIÈRE	HINGE ASSEMBLY
29	59 329	BUTÉE DE BRAS	LID ARM REST
30	59 315	DOUILLE DE CENTRAGE (x2)	CENTERING WASHER (x2)
31	59 330	VOYANT	LIGHT
32	59 331	SÉCURITÉ COUVERCLE	LID SECURITY
33	59 332	SECURITÉ DE BRAS	LID SUPPORT SECURITY
34	501 258S	INTERRUPTEUR SECURITE	SECURITY SWITCH
35	507 250S	INTERRUPTEUR SECURITE	SECURITY SWITCH
36	59 333	AXE CHARNIÈRE	HINGE PIN
37	59 484	BOUTON ARRÊT	STOP BUTON
38	59 487	BOUTON PULSE	PULSE BUTON
39	59 486	BOUTON II	II BUTON
40	59 485	BOUTON I	I BUTON
41	59 395	POIGNEE RACLEUR	BLIXER ARM HANDLE
42	59 391	ENSEMBLE RACLEURS COUVERCLE	LID SCRAPERS ASSEMBLY
43	59 335	CARTE DE COMMANDE	PCB
44	502 495S	FUSIBLE 10X38	10X38 FUSE
45	502 442S	FUSIBLE 5X20	5X20 FUSE
46	59 339	SUPPORT CARTE	PCB SUPPORT
47	59 336	FAISCEAU DE CONNEXION	CONNECTION WIRES
48	59 338	TRAPPE	FLAP DOOR
49	59 337	PROTECTION CARTE	PCB PROTECTION
50	59 340	JOINT TRAPPE ACCES	FLAP DOOR SEAL
51	59 341	CABLE	POWER CORD
52	501 773S	PASSE-FIL	WIRE DUCK
53	59 342	PIED COMPLET	FOOT ASSEMBLY
54	100 790S	PIED	FOOT
55	59 365	ENSEMBLE ROULETTE	CASTOR ASSEMBLY
56	500 551S	ROULETTE	CASTOR
57	59 453	ENSEMBLE CACHE-VIS (X4)	MOTOR BOLT CUP KIT (X4)
58	59 007	CONTACT PROTÉGÉ	PROTECTED SWITCH
59	59 009	BOUCHON COUVERCLE	LID CAP

Index	Désignation	Description
<b>A</b>	CUVE	BOWL
<b>B</b>	DEFLECTEUR ET GUIDE D'EAU	DEFLECTOR AND WATER PROTECTION
<b>C</b>	VENTILATEUR	MOTOR FAN
<b>D</b>	PLAQUE FRONTALE	FRONT PLATE
<b>E</b>	SOCLE	BASE ASSEMBLY
<b>F</b>	GUIDE D'AIR	AIR DEFLECTOR
<b>G</b>	ENS. BRAS RACLEUR	SCRAPER ARM ASSEMBLY
<b>H</b>	ENS. RACLEUR CUVE	SCRAPER BOWL ASSEMBLY
<b>I</b>	ENSEMBLE DE COMMANDE	COMMAND ASSEMBLY
<b>J</b>	RELAIS THERMIQUE	THERMAL RELAY
<b>K</b>	CONTACTEUR	CONTACTOR
<b>M</b>	MOTEUR	MOTOR

Type	Machine	Voltage	A	B	C	D	E	F
<b>BLIXER 15</b> - 532 ----- --	<b>TOUTES ALL</b>	<b>TOUS ALL</b>	<b>59 266</b>	<b>59 310</b>	<b>59 311</b>	<b>59 401</b>	<b>59 368</b>	<b>59 369</b>
	<b>Machine</b>	<b>Voltage</b>	<b>G</b>	<b>H</b>				
	<b>TOUTES ALL</b>	<b>TOUS ALL</b>	<b>59 383</b>	<b>59 386</b>				
	<b>Machine</b>	<b>Voltage</b>	<b>I</b>	<b>J</b>	<b>K</b>	<b>M</b>		
	<b>51 511</b>	<b>400/50/3</b>	<b>59 404</b>	<b>59 349</b>	<b>59 347</b>	<b>59 370</b>		
	<b>51 513</b>	<b>220/60/3</b>	<b>59 463</b>	<b>59 350</b>	<b>59 348</b>	<b>59 371</b>		
	<b>51 514</b>	<b>380/60/3</b>	<b>59 404</b>	<b>59 349</b>	<b>59 347</b>			
	<b>51 515</b>	<b>230/50/3</b>	<b>59 463</b>	<b>59 350</b>	<b>59 348</b>	<b>59 370</b>		
	<b>51 516</b>	<b>200/60/3</b>				<b>59 371</b>		

Type	Machine	Voltage	A	B	C	D	E	F
<b>BLIXER 20</b> - 534 ----- --	<b>TOUTES ALL</b>	<b>TOUS ALL</b>	<b>59 267</b>	<b>-</b>	<b>-</b>	<b>59 402</b>	<b>59 373</b>	<b>59 374</b>
	<b>Machine</b>	<b>Voltage</b>	<b>G</b>	<b>H</b>				
	<b>TOUTES ALL</b>	<b>TOUS ALL</b>	<b>59 384</b>	<b>59 387</b>				
	<b>Machine</b>	<b>Voltage</b>	<b>I</b>	<b>J</b>	<b>K</b>	<b>M</b>		
	<b>51 611</b>	<b>400/50/3</b>	<b>59 406</b>	<b>59 350</b>	<b>59 375</b>	<b>59 377</b>		
	<b>51 613</b>	<b>220/60/3</b>	<b>59 405</b>	<b>59 380</b>	<b>59 376</b>	<b>59 379</b>		
	<b>51 614</b>	<b>380/60/3</b>	<b>59 406</b>	<b>59 350</b>	<b>59 375</b>			
	<b>51 615</b>	<b>230/50/3</b>	<b>59 405</b>	<b>59 380</b>	<b>59 376</b>	<b>59 377</b>		
	<b>51 616</b>	<b>200/60/3</b>				<b>59 379</b>		



**robotcoupe®**

**BLIXER® 15E V.V.  
BLIXER® 20E V.V.**

N° de série / Serial number  
- 533 - - - - -  
- 535 - - - - -

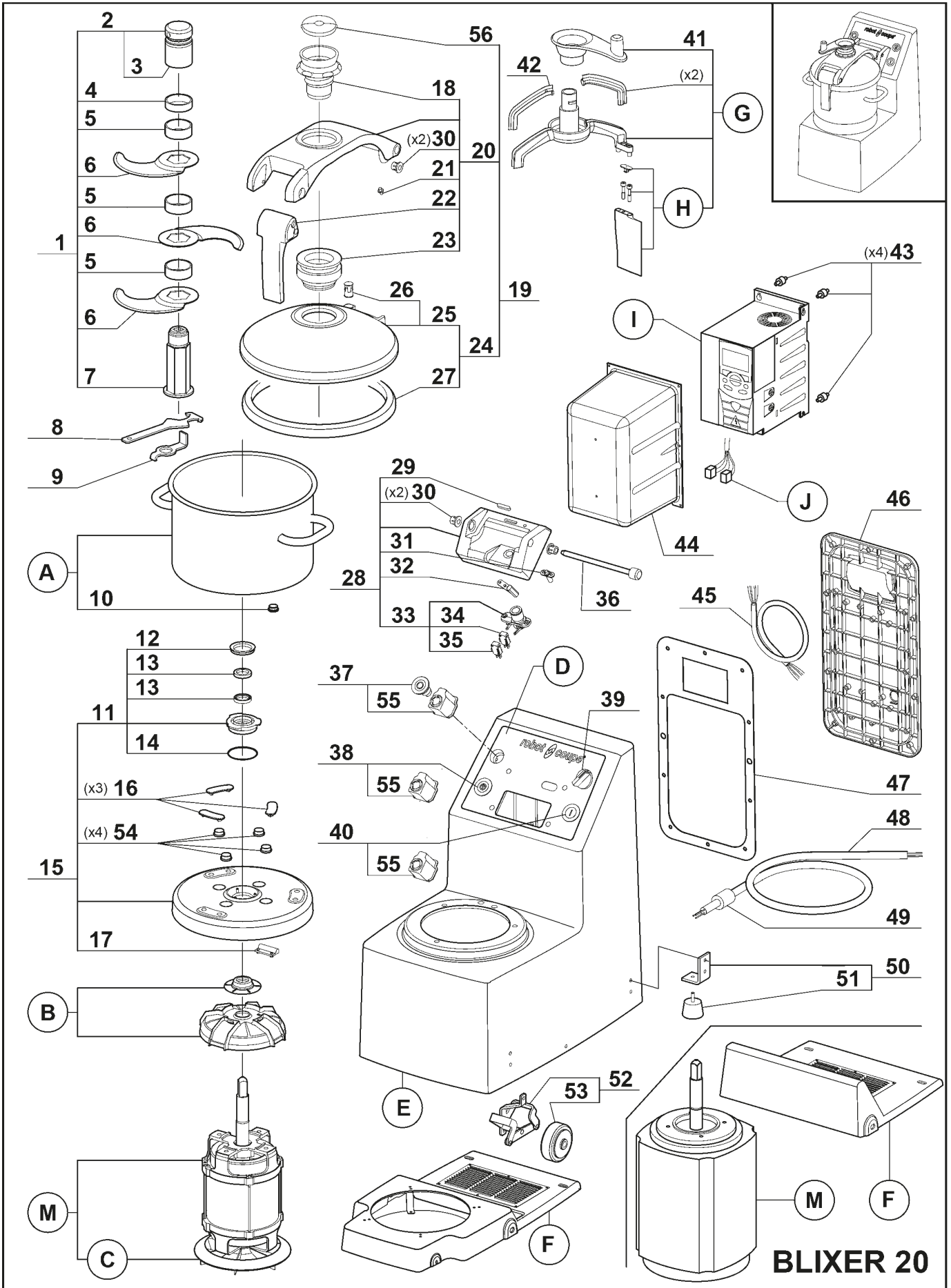

**BLIXER 20**

<i>Index</i>	<i>Pièce / Part</i>	<i>Désignation</i>	<i>Description</i>
1	<b>57 102</b>	ENS COUTEAU LAMES DENTÉES	FINE SERRATED BLADE ASSEMBLY
2	<b>59 396</b>	ECROU DE COUTEAU	BLADE LOCKING NUT
3	<b>117 225S</b>	BAGUE INOX 45 MM	STAINLESS STEEL 45 MM RING
4	<b>59 279</b>	BAGUE COUTEAU PLASTIQUE 15 MM	PLASTIC RING 15 MM
5	<b>100 792S</b>	BAGUE INOX 15 MM	STAINLESS STEEL 15 MM RING
6	<b>59 359</b>	LAME DENTÉE	FINE SERRATED BLADE
7	<b>101 967S</b>	SUPPORT COUTEAU	BLADE SUPPORT
8	<b>119 200S</b>	CLEF DEMONTE COUTEAU	KNIFE WRENCH
9	<b>59 291</b>	DEMONTE COUTEAU	KNIFE TOOL
10	<b>59 292</b>	AIMANT CUVE	BOWL MAGNET
11	<b>59 293</b>	DOUILLE PORTE JOINT	SEALING SOCKET
12	<b>500 901S</b>	JOINT V RING	V RING
13	<b>501 624S</b>	BAGUE ETANCHEITE	LIP SEAL
14	<b>502 670S</b>	JOINT TORIQUE	O RING
15	<b>59 360</b>	SUPPORT MOTEUR	MOTOR SUPPORT
16	<b>59 299</b>	APPUI CUVE (X3)	BOWL REST (X3)
17	<b>59 300</b>	SECURITE CUVE	BOWL SECURITY
18	<b>59 313</b>	CONE DE COUVERCLE	LID FUNNEL
19	<b>59 361</b>	ENS BRAS ET COUVERCLE	LID AND ARM ASSEMBLY
20	<b>59 389</b>	SUPPORT COUVERCLE	LID SUPPORT
21	<b>59 316</b>	DOIGT DE SÉCURITÉ	SECURITY PISTON
22	<b>59 317</b>	ENSEMBLE POIGNÉE	LID HANDLE ASSEMBLY
23	<b>59 318</b>	APPUI DE COUVERCLE	LID GUIDE
24	<b>59 362</b>	ENSEMBLE COUVERCLE	LID ASSEMBLY
25	<b>59 363</b>	COUVERCLE	LID
26	<b>59 321</b>	ENSEMBLE AIMANT COUVERCLE	LID MAGNET ASSEMBLY
27	<b>59 364</b>	JOINT DE COUVERCLE	LID GASKET
28	<b>59 328</b>	ENS CHARNIÈRE	HINGE ASSEMBLY
29	<b>59 329</b>	BUTÉE DE BRAS	LID ARM REST
30	<b>59 315</b>	DOUILLE DE CENTRAGE (x2)	CENTERING WASHER (x2)
31	<b>59 330</b>	VOYANT	LIGHT
32	<b>59 331</b>	SÉCURITÉ COUVERCLE	LID SECURITY
33	<b>59 332</b>	SECURITÉ DE BRAS	LID SUPPORT SECURITY
34	<b>501 258S</b>	INTERRUPTEUR SECURITE	SECURITY SWITCH
35	<b>507 250S</b>	INTERRUPTEUR SECURITE	SECURITY SWITCH
36	<b>59 333</b>	AXE CHARNIÈRE	HINGE PIN
37	<b>59 484</b>	BOUTON ARRÊT	STOP BUTON
38	<b>59 487</b>	BOUTON PULSE	PULSE BUTON
39	<b>59 001</b>	BOUTON POTENTIOMETRE	BUTON POTENTIOMETER
40	<b>59 485</b>	BOUTON I	I BUTON
41	<b>59 395</b>	POIGNEE RACLEUR	BLIXER ARM HANDLE
42	<b>59 391</b>	ENSEMBLE RACLEURS COUVERCLE	LID SCRAPERS ASSEMBLY
43	<b>59 408</b>	PLOTS (X4)	STUDS (X4)
44	<b>59 337</b>	PROTECTION CARTE	PCB PROTECTION
45	<b>59 407</b>	FAISCEAU V.V.	V.V. WIRES
46	<b>59 427</b>	TRAPPE V.V.	V.V. FLAP DOOR
47	<b>59 340</b>	JOINT TRAPPE ACCES	FLAP DOOR SEAL
48	<b>59 341</b>	CABLE	POWER CORD
49	<b>501 773S</b>	PASSE-FIL	WIRE DUCK
50	<b>59 342</b>	PIED COMPLET	FOOT ASSEMBLY
51	<b>100 790S</b>	PIED	FOOT
52	<b>59 365</b>	ENSEMBLE ROULETTE	CASTOR ASSEMBLY
53	<b>500 551S</b>	ROULETTE	CASTOR
54	<b>59 453</b>	ENSEMBLE CACHE-VIS (X4)	MOTOR BOLT CUP KIT (X4)
55	<b>59 007</b>	CONTACT PROTÉGÉ	PROTECTED SWITCH
56	<b>59 009</b>	BOUCHON COUVERCLE	LID CAP

Index	Désignation	Description
<b>A</b>	CUVE	BOWL
<b>B</b>	DEFLECTEUR ET GUIDE D'EAU	DEFLECTOR AND WATER PROTECTION
<b>C</b>	VENTILATEUR	MOTOR FAN
<b>D</b>	PLAQUE FRONTALE	FRONT PLATE
<b>E</b>	SOCLE	BASE ASSEMBLY
<b>F</b>	GUIDE D'AIR	AIR DEFLECTOR
<b>G</b>	ENS. BRAS RACLEUR	SCRAPER ARM ASSEMBLY
<b>H</b>	ENS. RACLEUR CUVE	SCRAPER BOWL ASSEMBLY
<b>I</b>	VARIATEUR	VARIATOR
<b>J</b>	FAISCEAU MOTEUR	MOTEUR WIRES
<b>M</b>	MOTEUR	MOTOR

Type	Machine	Voltage	A	B	C	D	E	F	G
<b>BLIXER 15</b> - 533 ----- --	<b>TOUTES ALL</b>	<b>TOUS ALL</b>	59 266	59 310	59 311	59 424	59 368	59 369	59 383
	<b>Machine</b>	<b>Voltage</b>	<b>H</b>	<b>M</b>					
	<b>TOUTES ALL</b>	<b>TOUS ALL</b>	59 386	59 370					
	<b>Machine</b>	<b>Voltage</b>	<b>I</b>	<b>J</b>					
	51 506	200-240/3	59 413	59 410					
	51 507	380-480/3	59 415	59 416					

Type	Machine	Voltage	A	B	C	D	E	F	G
<b>BLIXER 20</b> - 535 ----- --	<b>TOUTES ALL</b>	<b>TOUS ALL</b>	59 267	-	-	59 425	59 373	59 374	59 384
	<b>Machine</b>	<b>Voltage</b>	<b>H</b>	<b>M</b>					
	<b>TOUTES ALL</b>	<b>TOUS ALL</b>	59 387	59 377					
	<b>Machine</b>	<b>Voltage</b>	<b>I</b>	<b>J</b>					
	51 606	200-240/3	59 414	59 410					
	51 607	380-480/3	59 417	59 416					

R8E - R10E - R15E - R20E

BLIXER®8E - BLIXER®10E - BLIXER®15E - BLIXER®20E

200V/50-60Hz - 220V/60Hz - 230V/50Hz - 380V/60Hz - 400V/50Hz

SCHEMA ELECTRIQUE

ELECTRIC DIAGRAM

ELEKTRISCHES SCHALTBILD

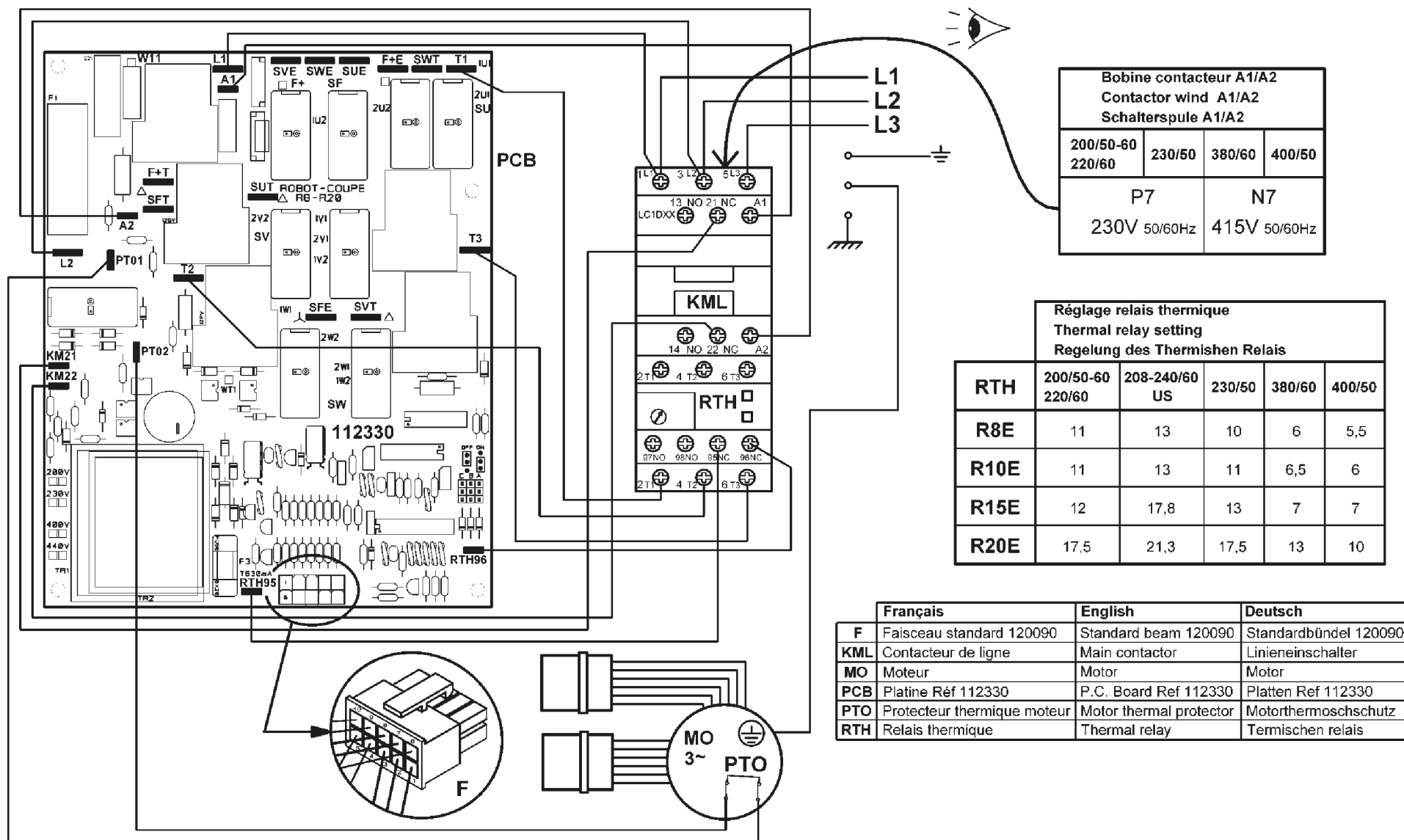

Bobine contacteur A1/A2 Contactor wind A1/A2 Schalterspule A1/A2			
200/50-60 220/60	230/50	380/60	400/50
P7 230V 50/60Hz		N7 415V 50/60Hz	

Réglage relais thermique Thermal relay setting Regelung des Thermischen Relais					
RTH	200/50-60 220/60	208-240/60 US	230/50	380/60	400/50
R8E	11	13	10	6	5,5
R10E	11	13	11	6,5	6
R15E	12	17,8	13	7	7
R20E	17,5	21,3	17,5	13	10

	Français	English	Deutsch
F	Faisceau standard 120090	Standard beam 120090	Standardbündel 120090
KML	Contacteur de ligne	Main contactor	Linienenschalter
MO	Moteur	Motor	Motor
PCB	Platine Réf 112330	P.C. Board Ref 112330	Platten Ref 112330
PTO	Protecteur thermique moteur	Motor thermal protector	Motorthermoschutz
RTH	Relais thermique	Thermal relay	Thermischen relais

# R8E - R10E - R15E - R20E

200V/50-60Hz - 220V/60Hz - 230V/50Hz - 380V/60Hz - 400V/50Hz

SCHEMA ELECTRIQUE

# BLIXER®8E - BLIXER®10E - BLIXER®15E - BLIXER®20E

ELECTRIC DIAGRAM

ELEKTRISCHES SCHALTBILD

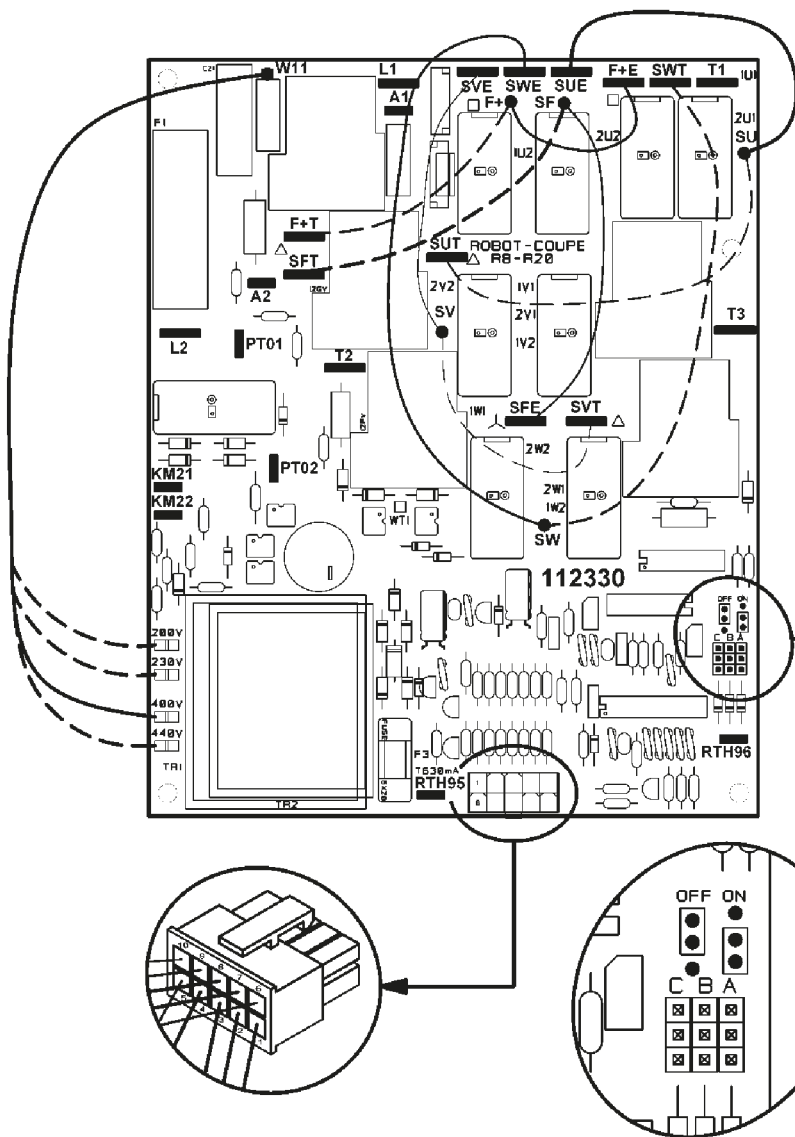

## CHECK LIST



Il y a 6 fils à commuter suivant la tension d'alimentation + contrôle tension bobine.  
**There are 6 wires to connect according to the supply voltage + check voltage wind.**  
 Es gibt 6 Kabeln müssen ungeschalt werden entsprechend der Stromversorgung  
 + Spannungskontrolle windt auf.

**LE NON RESPECT DE CES INSTRUCTIONS DE CABLAGE ANNULERA VOTRE GARANTIE.  
 FAILURE TO FOLLOW THESE WIRING INSTRUCTIONS WILL VOID YOUR WARRANTY.  
 BEI NICHTBEFOLGUNG DER VERKABELLUNGSANLEITUNGEN VERFALT DIE GARANTIE.**

		Tension d'alimentation / Supply voltage / Stromspannung			
Fils Wires Kabeln		200 V	220 V - 230 V	380 V - 400 V	440 V
W11		200 V	230 V	400 V	440 V
gris / gray / grau	F+	F+T		F+E	
bleu / blue / blau	SF	SFT		SFE	
blanc / white / weiß	SU	SUT		SUE	
rouge / red / rot	SV	SVT		SVE	
jaune / yellow / gelb	SW	SWT		SWE	

# R8E - R10E - R15E - R20E

# BLIXER® 8E - BLIXER® 10E - BLIXER® 15E - BLIXER® 20E

200V/50-60Hz - 220V/60Hz - 230V/50Hz - 380V/60Hz - 400V/50Hz

SCHEMA ELECTRIQUE

ELECTRIC DIAGRAM

ELEKTRISCHES SCHALTBILD

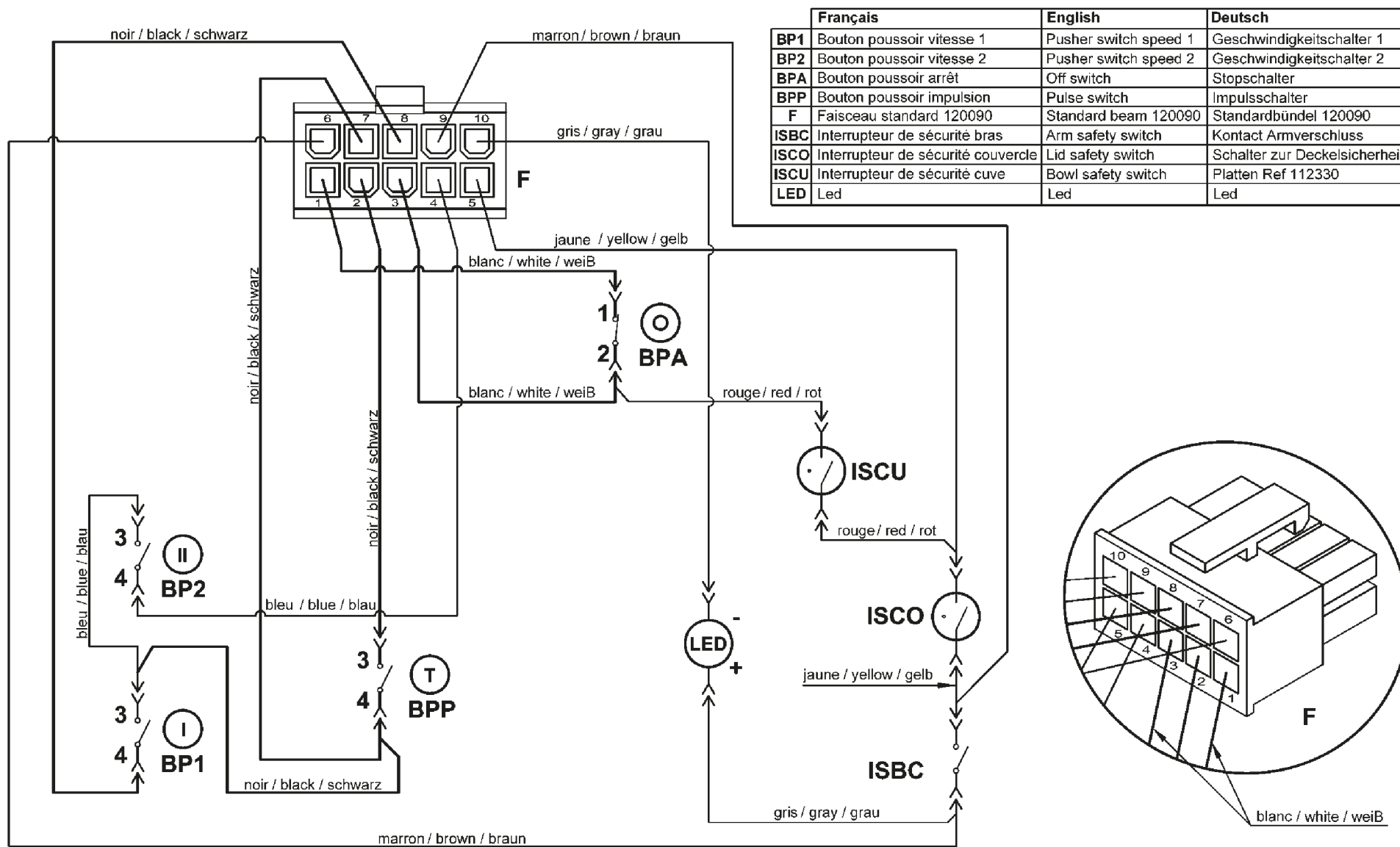

	Français	English	Deutsch
BP1	Bouton poussoir vitesse 1	Pusher switch speed 1	Geschwindigkeitschalter 1
BP2	Bouton poussoir vitesse 2	Pusher switch speed 2	Geschwindigkeitschalter 2
BPA	Bouton poussoir arrêt	Off switch	Stopschalter
BPP	Bouton poussoir impulsion	Pulse switch	Impulsschalter
F	Faisceau standard 120090	Standard beam 120090	Standardbündel 120090
ISBC	Interrupteur de sécurité bras	Arm safety switch	Kontakt Armverschluss
ISCO	Interrupteur de sécurité couvercle	Lid safety switch	Schalter zur Deckelsicherheit
ISCU	Interrupteur de sécurité cuve	Bowl safety switch	Platten Ref 112330
LED	Led	Led	Led

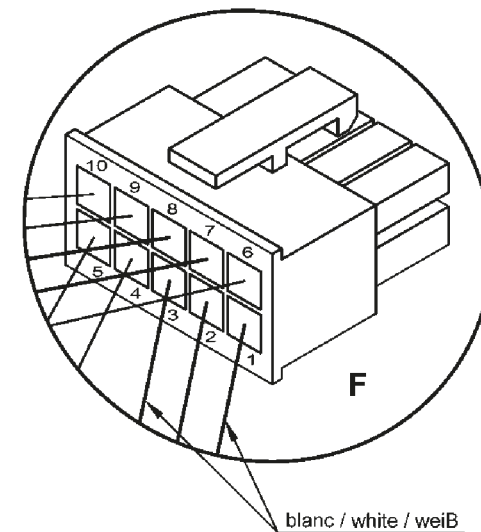

R8E - R10E - R15E - R20E V.V.

BLIXER®8E - BLIXER®10E - BLIXER®15E - BLIXER®20E V.V.

200-240V/50-60Hz 1~ - 200-240V/50-60Hz 3~ - 380-480V/50-60Hz 3~

SCHEMA ELECTRIQUE

ELECTRIC DIAGRAM

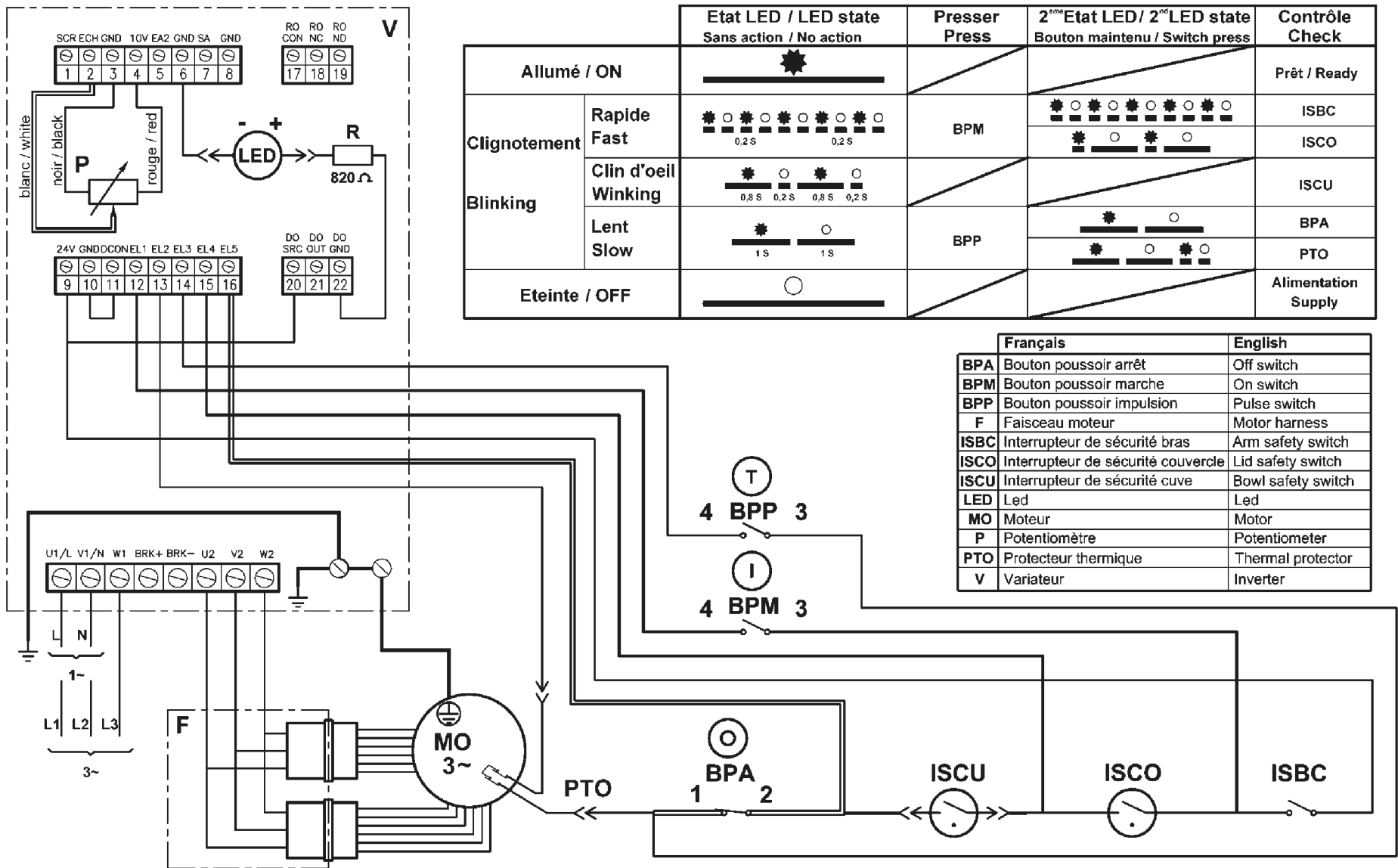

		Etat LED / LED state Sans action / No action	Presser Press	2 <sup>ème</sup> Etat LED / 2 <sup>nd</sup> LED state Bouton maintenu / Switch press	Contrôle Check
Allumé / ON			/	/	Prêt / Ready
Clignotement Blinking	Rapide Fast		BPM		ISBC
	Clin d'oeil Winking		/	/	ISCO
			BPP		ISCU
			/		BPA
			/		PTO
Eteinte / OFF			/	/	Alimentation Supply

	Français	English
BPA	Bouton poussoir arrêt	Off switch
BPM	Bouton poussoir marche	On switch
BPP	Bouton poussoir impulsion	Pulse switch
F	Faisceau moteur	Motor harness
ISBC	Interrupteur de sécurité bras	Arm safety switch
ISCO	Interrupteur de sécurité couvercle	Lid safety switch
ISCU	Interrupteur de sécurité cuve	Bowl safety switch
LED	Led	Led
MO	Moteur	Motor
P	Potentiomètre	Potentiometer
PTO	Protecteur thermique	Thermal protector
V	Variateur	Inverter

robot@coupe®

N° 402834 (b)

Maj : 09/10



**robot coupe**<sup>®</sup>

**Head Office, French,  
Export and Marketing Department:**  
48, rue des Vignerons  
94305 Vincennes Cedex- France  
Tel.: 01 43 98 88 15 - Fax: 01 43 74 36 26  
Email: international@robot-coupe.com

**Robot Coupe Australia Pty Ltd:**  
Unit 3/43 Herbert St  
Artarmon NSW 2064 Australia  
Tel.: (02) 9478 0300  
Fax (02) 9460 7972  
Email: orders@robotcoupe.com.au

**Robot-Coupe U.K. LTD:**  
Fleming Way, Isleworth,  
Middlesex TW7 6EU  
Tel.: 020 8232 1800  
Fax: 020 8568 4966  
Email: sales@robotcoupe.co.uk